

## Translation of the Original Operating Manual Mobile energy storage system – BattPak 3621



**Read operating manual before starting any work!  
Keep the operating manual for future use!**

Revision			
Date	Chapter	Reason for change	Person responsible
06-25		New creation	R&D
10-25		Revision	R&D

Revision status: 10-2025  
Serial number:

© Gölz GmbH  
Dommersbach 51  
D- 53940 Hellenthal

Tel.: +49 (0)2482 – 12 200  
Fax: +49 (0)2482 – 12 222

email: [info@goelz.de](mailto:info@goelz.de)  
website: [www.goelz.de](http://www.goelz.de)

**1 Content**

<b>1 Content</b>	<b>3</b>
<b>2 General</b>	<b>5</b>
2.1 Operating manual	5
2.2 Symbols, acronyms, terminology	5
2.3 Explanation of symbols	5
2.4 Liability limitation	6
2.5 Customer service	7
2.6 Copyright	7
<b>3 Safety</b>	<b>8</b>
3.1 Intended use	8
3.2 Rationally foreseeable misuse	8
3.3 Responsibilities of the operator	8
3.4 User Requirements	9
3.5 Dangers	9
3.5.1 Safety-Compliant Condition	10
3.5.2 Risks through electrical hazards	11
3.5.3 Risks due to hazardous substances	13
3.6 Safety	13
3.6.1 General safety instructions	13
3.6.2 Safety devices	14
3.7 Spare parts	15
3.8 Actions in emergency and in case of accidents	15
3.9 Signage	16
3.9.1 Legend to symbols	16
3.9.1.1 BattPak 3621	16
3.9.1.2 GÖLZ-APP	16
<b>4 Technical data</b>	<b>18</b>
4.1 Dimensions	18
4.2 Load in line mode	18
4.3 Load in battery mode	18
4.4 Charging	18
4.5 Information of battery cells and battery	19
4.6 Connections	19
4.7 Operating conditions	19
4.8 Type plate	19
4.9 Installation site requirements	20
4.10 Storage requirements	20
<b>5 Design and function</b>	<b>21</b>
5.1 Scope of delivery and responsibility	21
5.2 BattPak 3621	21
5.2.1 Functional description	23
<b>6 Transport &amp; packaging</b>	<b>24</b>
6.1 Transport safety information	24
6.2 Transport inspection	24
6.3 Transport symbols	24
6.4 Transport and storage	25
<b>7 Installation and first commissioning</b>	<b>27</b>
7.1 Location	27
7.2 First commissioning and acceptance, general	27
<b>8 Operation</b>	<b>28</b>
8.1 Operation safety information	28
8.1.1 Power Distributor	28

8.2	Start-up preparation .....	28
8.3	Power switch .....	29
8.4	Operation/charging via 230V .....	29
8.4.1	AC- input .....	29
8.4.2	AC-Output .....	30
8.4.3	USB-Output.....	31
8.5	Charging via photovoltaics (PV) .....	31
8.5.1	Charging via GÖLZ®- solar panel BL 400 .....	31
8.6	APP Connection .....	32
8.6.1	GÖLZ®-App.....	32
8.7	UPS Function.....	36
8.8	Expanded Battery Pack Xpansion 2100 .....	36
<b>9</b>	<b>Maintenance &amp; cleaning.....</b>	<b>38</b>
9.1	Maintenance safety information .....	38
9.2	Maintenance plan .....	38
9.3	Description of the maintenance works to be carried out by the operator .....	39
9.3.1	Fan Replacement.....	39
9.4	Steps after completing maintenance .....	39
<b>10</b>	<b>Errors .....</b>	<b>40</b>
10.1	Troubleshooting safety information .....	40
10.2	Actions in case of errors .....	40
10.3	Troubleshooting table .....	41
10.4	Fault Code Summary Table.....	41
10.5	Steps after troubleshooting.....	42
<b>11</b>	<b>Disposal.....</b>	<b>43</b>
<b>12</b>	<b>Index .....</b>	<b>44</b>
	<b>EU conformity declaration .....</b>	<b>45</b>

## 2 General

### 2.1 Operating manual

- ▶ This operating manual contains all important information for the safe and proper use of the BattPak. It is an integral part of the BattPak and must always be kept readily accessible to operating and maintenance personnel.
- ▶ Safe operation requires careful observance of all safety and operating instructions in this manual.
- ▶ Read all safety and warning notices, terms of use, and liability disclaimers carefully.
- ▶ Users assume full responsibility for the use and operation of the BattPak.
- ▶ Familiarize yourself with the relevant regulations in your country.
- ▶ You are solely responsible for knowing all applicable regulations and using the BattPak in accordance with them.
- ▶ In addition, all accident prevention regulations and general safety rules applicable at the place of use must be observed.
- ▶ Before starting operation, read the operating instructions of the connected device.

### 2.2 Symbols, acronyms, terminology

Symbols, acronyms and specialist terminology used in this document have the following meaning:

- See item
- ▶ Enumeration
- Enumeration
- 1 Position number
- 1. Action step
- Text in italics* Explanation of facts
-  Refers to the document contained in the enclosed documentation. The source of the document is specified in italics behind the symbol.

### 2.3 Explanation of symbols

#### Warnings and safety instructions

Warnings and safety instructions in the manual are identified with the pictograms and provided in blocks highlighted in grey.

Warnings and safety instructions, which draw attention to fundamental dangers, are additionally precluded by signal words, which specify the scope of damage. Their structure is as follows:

**SIGNAL WORD!**  
**Origin of the danger.**  
Consequences of ignoring the danger.  
- Actions to avoid danger

- ▶ All warnings and safety instructions must be implicitly complied with!
- ▶ During the works, always act with caution, to avoid accidents, personal and material damage!

Pictograms combined with signal words mean:



**DANGER!**  
... Indicates an immediate hazard that will result in serious injury or death. Always follow safety instructions and precautions.



**WARNING:**

... Indicates a potentially hazardous situation that could result in serious injury or death.



**CAUTION!**

... Indicates a potentially hazardous situation that could result in minor or moderate injury.



**ATTENTION!**

... Indicates a potentially hazardous situation that could result in property damage.

**Tips and recommendations**



**NOTE!**

... highlights tips and recommendations as well as information on efficient and trouble-free operation.

**Special safety instructions**

To make aware of special dangers, the following pictograms are used in combination with the safety instructions:



... marks danger due to electric current.  
Failure to observe the safety instructions leads to danger of heavy or fatal injuries.  
Observe safety instructions regarding the electrical connection and related measures.



Protect the BattPak from heat and fire.



Do not immerse the BattPak in liquids.

**2.4 Liability limitation**

All data and instructions provided in this manual were compiled with consideration of applicable standards and regulations, state of the art in this field and our long-standing insights and experience.

The manufacturer accepts no liability for damages caused by:

- ▶ Non-observance of the Operating manual
- ▶ Unintended use
- ▶ Employment of unskilled and uninstructed personnel
- ▶ Unauthorised conversions
- ▶ Technical changes
- ▶ Use of non-approved spare parts

The responsibilities agreed in the delivery contract, the General Terms and Conditions as well as the delivery conditions of the manufacturer and the statutory regulations valid at the time of the conclusion of the contract shall apply.

### Warranty

The manufacturer guarantees the functional capability of the applied process technology and performance parameters identified.

The warranty period commences with the defect-free delivery.

If you have any questions regarding the warranty conditions, please contact your local partner.

### Wear parts

Wear parts are all parts having direct contact with the processed or machined material during normal operation.

These parts are excluded from warranty and defect claims, insofar as tear and wear resulting from normal operation.

### Warranty conditions

The warranty period begins on the date the original purchaser receives the products. The purchase receipt (invoice) serves as proof of warranty.

- ▶ All batteries in BattPak products are covered by a 5-year warranty.
- ▶ All mechanical and electronic components are covered by a 2-year warranty.
- ▶ Cables/adapters/connectors cannot be registered for warranty. In case of quality issues with these products, please contact our service team directly at [service@goelz.de](mailto:service@goelz.de).

The full warranty terms are included with the purchase of a BattPak or can be viewed online at:

<https://battpak.de/pages/garantiebestimmungen>

## 2.5 Customer service

Our customer service department is available to provide technical information.

**Service hotline**  
**02482 – 12 200**

You can obtain tips via the regional competent contact person by phone or via fax, email or website at any time.

Moreover, our employees are interested in new information and experience arising from use and which can be valuable for the improvement of our products.

## 2.6 Copyright

This document is protected by copyright. An unauthorised transfer to third parties, duplication of any kind, including in parts, as well as use and/or disclosure of the content without written permission of the publisher is prohibited.

Non-compliance with this provision is subject to damages. The right for further claims remains reserved.

### 3 Safety

This section provides an overview of all safety aspects of protection of operators and users from potential dangers, and safe and trouble-free operation.  
Disregarding these handling instructions, warnings and safety instructions may pose serious risks.

#### 3.1 Intended use

The BattPak 3621 is designed exclusively for the following purposes:

##### **The BattPak 3621**

- The BattPak 3621 is a portable energy system. It is designed to operate wired devices and supplies electrical power to an electronic appliance.
- The BattPak is built to protection class IP67 and can be used in rainy conditions.



##### **WARNING: Risk of unintended use!**

Any use beyond the intended use of the BattPak may result in dangerous situations.

- The BattPak must be basically used for the intended purpose according to data contained in this document, in particular, within the application limits provided in the technical data.
- Refrain from any use beyond this scope or different use of the BattPak.
- Refrain from remodelling, refitting or changing the design or separate parts of the BattPak for the purpose of changing the field of application or applicability of the BattPak.

- ▶ Any claims for damages resulting from unintended use are excluded.
- ▶ The operator alone is responsible for all damages due to unintended use.

#### 3.2 Rationally foreseeable misuse



##### **WARNING: Risk of injury caused by misuse!**

When misused, the BattPak may create dangerous situations for persons and cause heavy material damage.

- Refrain from any misuse of the BattPak.

Any use of the machine going beyond the intended one, shall be deemed unintended and thus prohibited.  
Use the BattPak 3621 only as described in this operating manual.

#### 3.3 Responsibilities of the operator

##### **Operator**

An operator is every natural or legal person, who uses the BattPak or delegates its use to others and is responsible for the safety of the user, personnel or third parties in the course of such use.

##### **Operator's duties**

The BattPak is used in the commercial sector. Therefore, the operator of the BattPak is subject to statutory obligations regarding occupational safety.

## 3.4 User Requirements



### CAUTION!

Read, understand, and keep the operating manual!

- ▶ If the portable energy storage system is passed on to another person, the operating manual must be included.
- ▶ Ensure that the user meets the following requirements:
  - The user is physically, sensorily, and mentally capable of operating the portable energy storage system. If the user has physical, sensory, or mental limitations, they may only operate the system under supervision or according to the instructions of a responsible and qualified person.
  - The user is able to recognize and assess the hazards associated with the portable energy storage system.
  - The user is of legal age or is being trained in a profession under supervision in accordance with national regulations.
  - The user has received instruction from a Gölz sales partner or a qualified person before using the portable energy storage system for the first time.
  - The user is not under the influence of alcohol, medication, or drugs.

### Qualification



### WARNING:

#### Risk of injury for unqualified personnel!

Improper operation can result in significant personal and material damage.

- Any operations must be only carried out by the persons having required training, knowledge and experience.

As a matter of principle, all works on the electrical installations must be carried out by qualified electricians.

Qualified electricians are the persons, who, due to their specialist training, knowledge and experience, as well as knowledge of the relevant provisions, are capable of duly carrying out the works on electrical systems, recognising potential dangers independently and avoiding personal and material damage caused by electric current.

## 3.5 Dangers

The identified hazards have been eliminated as far as possible, and recognized risks have been reduced. Nevertheless, residual risks remain with the energy storage system BattPak, which are described in the following section.

- ▶ Always observe the warning and safety instructions listed here and in the operational chapters of this manual to avoid potential health hazards and dangerous situations.



### GEFAHR!

Uninvolved persons, children, and animals may not recognize or properly assess the dangers of the mobile energy storage system.

- ▶ Uninvolved persons, children, and animals may suffer serious injuries.
- ▶ Keep uninvolved persons, children, and animals away.
- ▶ Ensure that children cannot play with the mobile energy storage system.
- ▶ The mobile energy storage system is not protected against all environmental influences.

- ▶ If the mobile energy storage system is exposed to certain environmental conditions, it may catch fire, explode, or become irreparably damaged. This can lead to serious injury and property damage.



- ▶ Protect the energy storage system from heat and fire.
- ▶ Do not throw the energy storage system into fire.
- ▶ Do not charge, use, or store the energy storage system outside the specified temperature range.



- ▶ Do not immerse the energy storage system in liquids.
- ▶ Do not expose the system BattPak to high pressure.
- ▶ Do not expose BattPak to microwaves.
- ▶ Protect BattPak from chemicals and salts.
- ▶ Do not operate the BattPak in easily flammable or explosive environments.
- ▶ Do not operate the BattPak on flammable surfaces.
- ▶ If the BattPak must be used on an aerial work platform or a secure scaffold: Secure the BattPak with fall protection to prevent it from falling.
- ▶ If the BattPak is used as a work surface, it may become damaged. This can lead to personal injury and property damage.
- ▶ Do not use the BattPak as a work surface.

### 3.5.1 Safety-Compliant Condition

The BattPak is in a safety-compliant condition if the following requirements are met:

- ▶ The BattPak is undamaged.
- ▶ The BattPak is clean and dry.
- ▶ The BattPak is functioning properly and has not been modified.
- ▶ The fall protection system is undamaged and unmodified.
- ▶ Original GÖLZ accessories for this storage system are attached.
- ▶ The accessories are properly installed.



#### **WARNING!**

If the BattPak is not in a safety-compliant condition, it can no longer operate safely. Serious injury may occur.

- ▶ Only use an undamaged and properly functioning BattPak.
- ▶ Do not charge a damaged or defective BattPak.
- ▶ If the BattPak is dirty or wet: clean and allow it to dry completely.
- ▶ Do not modify the BattPak.
- ▶ Do not insert objects or foreign materials into the openings of the BattPak.
- ▶ Do not connect or short-circuit the BattPak's electrical contacts with metallic objects.
- ▶ Do not open the BattPak.
- ▶ Install accessories only as described in this user manual or in the accessory's user manual.
- ▶ Replace worn or damaged warning labels.



**WARNING!**

Fluid may leak from a damaged BattPak. If the fluid comes into contact with the skin or eyes, it may cause irritation.

- ▶ Avoid contact with the fluid.
- ▶ If contact with skin occurs: Wash affected areas thoroughly with plenty of water and soap.
- ▶ If contact with eyes occurs: Rinse eyes with plenty of water for at least 15 minutes and seek medical attention.



**DANGER!**

A damaged or defective B may emit an unusual odor, smoke, or catch fire. Serious injury or death to persons and property damage may result.

- ▶ If BattPak emits an unusual odor or smokes: Do not use the energy storage system and keep it away from flammable materials.
- ▶ If BattPak is on fire: Attempt to extinguish it using a fire extinguisher or water.
- ▶ In case of emergency, call the fire department (112).



**WARNING!**

Hazards while charging the BattPak

- ▶ During charging, a damaged or defective portable power supply or charging cable may emit an unusual odor or smoke.
- ▶ Injury to persons and property damage may occur.
- ▶ Unplug the charging cable from the wall socket.



**WARNING!**

Hazards from electrically connected BattPak

Contact with live components may result from the following causes:

- ▶ The charging cable or extension cord is damaged.
- ▶ The plug of the charging cable or extension cord is damaged.
- ▶ The socket connected to the power supply is not properly installed.

### 3.5.2 Risks through electrical hazards

#### Electric current



**DANGER!**

**Danger to life from electric current!**

Touching live parts leads to death. Damaged insulation or individual components can be life-threatening.

- Before performing maintenance, cleaning, or repair work, switch off the BattPak and disconnect all charging ports and consumers from the battery.
- Turn off the BattPak and disconnect it from the mains before connecting the PV-IN cable or the DC-IN cable.
- If the protective caps or plugs of the AC-IN, PV-IN, or DC-IN are damaged, turn off the BattPak immediately and arrange for repairs.
- If the power supply insulation is damaged, switch off immediately and arrange for repairs.
- Never bypass or disable fuses.
- Keep moisture away from live parts.
- The BattPak must not be opened under any circumstances!

- ▶ Ensure that the charging cable, extension cord, and their power plugs are undamaged.
- ▶ If the charging cable or extension cord is damaged:  
Do not touch the damaged area.  
Unplug the power plug from the socket.
- ▶ Only handle the charging cable, extension cord, and their power plugs with dry hands.
- ▶ Plug the power plug of the charging cable or the extension cord into a properly installed and protected socket with a grounding contact.
- ▶ Connect the charging cable via a residual current device (RCD) with 30 mA sensitivity and 30 ms tripping time.
- ▶ If the charging cable or the extension cord needs to be connected or disconnected: Always grasp the plug, never pull on the cable.
- ▶ A damaged or unsuitable extension cord can result in electric shock.
- ▶ People can be seriously injured or killed.
- ▶ Use an extension cord with the correct wire cross-section.
- ▶ If the BattPak is being charged or used outdoors:  
Use a splash-proof extension cord suitable for outdoor use.

**WARNING!**

Incorrect mains voltage or frequency during charging can lead to overvoltage in the BattPak.  
The BattPak may be damaged.

- ▶ Ensure that the mains voltage and frequency match the specifications on the BattPak's rating label.
- ▶ If the BattPak is being charged in a vehicle: Ensure that the voltage and frequency in the vehicle match the specifications on the BattPak's rating label.

**DANGER!**

**People may be seriously injured or killed, and property damage may occur.**

- If the BattPak is connected to a power strip, electrical components may become overloaded during charging.
- Electrical components may heat up and cause a fire.
- ▶ Ensure that the total power rating on the power strip is not exceeded by the sum of the portable power supply's rating and the ratings of all devices connected to the power strip.

**WARNING!**

**People may be injured, and the charging cable or extension cord may be damaged.**

- Improperly laid charging cables or extension cords can become damaged, and people may trip over them.
- ▶ Lay and mark the charging cable and extension cord in such a way that people cannot trip over them.
- ▶ Lay the charging cable and extension cord in a way that they are not stretched or tangled.
- ▶ Lay the charging cable and extension cord so that they are not damaged, bent, pinched, or chafed.
- ▶ Protect the charging cable and extension cord from heat, oil, and chemicals.
- ▶ Lay the charging cable and extension cord on a dry surface.
- ▶ During use, the extension cord heats up. If the heat cannot dissipate, it may cause a fire.
- ▶ If using a cable reel:  
Fully unwind the cable reel.



**WARNING!**

**People may be injured and property damage may occur.**

- The BattPak may be used and charged in a vehicle.
  - If the BattPak is not used or charged properly in a vehicle, vehicle components may be damaged.
- 
- ▶ Secure the BattPak in such a way that it cannot tip over or move during driving.
  - ▶ Do not permanently install the BattPak in the vehicle and do not use it continuously in the vehicle.
  - ▶ Comply with applicable national installation regulations when connecting to the vehicle's power supply system.

### 3.5.3 Risks due to hazardous substances



**CAUTION!**

**Risk of injury due to improper handling of lithium-ion batteries!**

Failure to wear appropriate protective equipment can result in serious injury.

- Store lithium-ion batteries according to regulations
- Avoid short circuits



**CAUTION!**

**Risk of injury Hazardous substances, such as escaping chemicals or chemical vapors!**

- Failure to wear suitable protective equipment can lead to damage to health.
  - Use personal protective equipment
  - Never touch chemicals
  - In case of escaping chemicals or chemical vapors, leave the danger zone immediately!
- If the battery cells are damaged, switch off the battery immediately and get help if chemicals are leaking. Never continue to use the battery with a damaged battery cell.

## 3.6 Safety

### 3.6.1 General safety instructions



**CAUTION!**

**Observe the following safety instructions for the safe handling and use of Li-ion batteries.**

Failure to comply may lead to

- Irritation
- severe corrosive injuries,
- chemical burns,
- Fire and/or lead to explosions.

- ▶ Use the BattPak and accessories only in perfect technical condition
- ▶ Never tamper with or change the BattPak or accessories. The BattPak must not be opened.
- ▶ Do not touch the electrical contacts with your fingers, tools, jewelry, or other electrically conductive objects.

- ▶ Do not short-circuit the outputs of the BattPak.
- ▶ Close the protective caps of the connectors when not in use.
- ▶ The BattPak must not be disassembled, crushed, heated above 60°C or burned.
- ▶ Never expose the BattPak to direct sunlight, increased temperature, sparking or open flame. This can lead to explosions.
- ▶ Keep the BattPak away from moisture and liquids. Moisture ingress can cause short circuits, electric shocks, burns, fire, and explosions.
- ▶ Do not use or store the BattPak in potentially explosive environments.
- ▶ Use the BattPak only within the defined limits of use.
- ▶ Handle the product carefully to avoid damage and prevent the leakage of liquids that are highly harmful to health!
- ▶ Make sure that the BattPak stands securely when using it. Place the BattPak only on a non-slip surface. Avoid protruding the product over an edge.
- ▶ Make sure that the cable length of the connected consumer is sufficient, the connecting cable must not be under tension.
- ▶ Do not use or charge the BattPak if it has received a blow or is otherwise damaged. Periodically inspect the BattPak for signs of damage.
- ▶ Do not use the product as a conductor replacement.
- ▶ Do not transport the BattPak on a crane or with lifting equipment.
- ▶ Comply with your local regulations for the safe operation of electrical consumers.
- ▶ Do not connect defective consumers to the BattPak.
- ▶ Do not connect generators to the outputs of the BattPak.
- ▶ Charge the BattPak only with the supplied charging cable.
- ▶ Make sure the consumer is turned off before connecting the consumer. Always switch off the consumer after use.
- ▶ Do not use the BattPak to operate life-sustaining medical consumers.
- ▶ If the BattPak is too hot to touch, it may be defective. Place the BattPak in a visible, non-flammable place at a sufficient distance from combustible materials. Let it cool. If the BattPak is still too hot to touch after an hour, then it is defective. Please contact the GÖLZ® service.

### 3.6.2 Safety devices



**WARNING:**  
**Danger to life due to defective or bypassed safety devices!**

Inoperable, bypassed or disabled safety devices do not protect from hazards and may lead to heavy or fatal injuries.

- Before commencement of works, always make sure that all safety devices are properly installed and functional.
- Never disable safety devices.
- Ensure that the safety devices are always freely accessible.



**NOTE!**  
 See safety devices in → "Design and function".

#### Emergency switch off

Under normal condition, the emergency stop switch is on (Pulled out), and the system is in normal working condition.

When emergency occurs, press down the emergency stop switch, the system control cuts off the input and output and prohibits charging and discharging.



**NOTE!**

*After the emergency stop switch restarts, the product would not start the work immediately, you need to press the power button to turn off the power and press the power button again to allow input and output functioning.*

### 3.7 Spare parts



**WARNING:**  
**Risk of injury due to wrong spare parts.**

Wrong spare parts can seriously compromise safety and cause damage and malfunction up to total failure.

- As a matter of principle, only original spare parts must be used.

Original spare parts can be obtained via an authorised dealer or directly from the manufacturer.

### 3.8 Actions in emergency and in case of accidents

**Necessary actions**

- ▶ Always be prepared for accidents or fire.
- ▶ First aid facilities (first aid box, cloth, etc.) and fire extinguisher must be close at hand.
- ▶ Personnel must familiarise themselves with accident signalling equipment, first aid and rescue facilities.
- ▶ Access roads for rescue vehicles must be always kept free.

**If the need arises, act properly**

- ▶ Activate emergency stop immediately
- ▶ Initiate first aid measures
- ▶ Remove persons affected from the danger area.
- ▶ Inform persons responsible at the operation site.
- ▶ Alert doctor and/or fire brigade in case of heavy injuries.
- ▶ Keep access roads for rescue vehicles free

## 3 Safety

### 3.9 Signage

#### Danger from electric current!



**DANGER!**  
**Danger to life from electric current!**

Touching live parts leads to death. Damage to the insulation or individual components can be life-threatening.

- The battery must not be opened under any circumstances!
- If the insulation is damaged, switch off the battery immediately and arrange for repairs.
- Keep moisture and moisture away from the live parts.

#### Illegible signs



**CAUTION!**  
**Risk of injury due to illegible symbols!**

Stickers and signs that got illegible, make danger zones insufficiently recognisable and may become incapable of indicating potential injury risks.

- Always maintain legibility of pictograms, safety, warning and operating instructions.
- Immediately replace the pictograms, labels, signs or stickers that became illegible.





#### 3.9.1 Legend to symbols

##### 3.9.1.1 BattPak 3621



	CE label		Transport label
	Restriction of Hazardous Substances Directive		Protection class
	WEEE-symbol		Recycling-symbol

##### 3.9.1.2 GÖLZ-APP

	Power capacity 2168 Wh 40,15 V, 54 Ah		Battery type Semi solid state Lithium ternary 54 Ah
	AC output (rated) 3600 W		AC output (Max) 18000 W
	Net weight 55.1 pound 25.0 kg		Dimension 22,1 x 10,2 x 16,1 Zoll 562 x 260 x 410 mm
	Cycle life 80 % of battery capacity remaining after 4000 cycles		

 <p>AC INPUT 220-240VAC, 50/60Hz, Max power 1600W</p>	 <p>PV INPUT 60-160VDC/15A, Max power 1600W</p>
 <p>AC OUTPUT 230VAC, 50/60Hz, Max power 3600W</p>	 <p>USB-C Output 5VDC/3A, 9VDC/2.22A 12VDC/1.66A, Max power 60W</p>

**APP**

Bluetooth/WIFI



Batterie



UPS



Discharging Temperature  
6 to 124°F / -18 to 60°C



Charging Temperature  
32 to 104°F / 0 to 40°C



**IP67**



**Protections**

- Over heat
- Short circuit
- Over current
- Over voltage
- Over charging
- Over discharging

- ▶ Do not charge the portable power supply at temperatures below  $-0^{\circ}\text{C}$  or above  $+40^{\circ}\text{C}$ .
- ▶ Do not use the portable power supply at temperatures below  $-18^{\circ}\text{C}$  or above  $+60^{\circ}\text{C}$ .
- ▶ Do not store the portable power supply at temperatures below  $-18^{\circ}\text{C}$  or above  $+40^{\circ}\text{C}$ .

**4 Technical data**
**4.1 Dimensions**

Specification	Value	Unit
Length	562	mm
Width	260	mm
Height	410	mm
Weight	25	kg

**4.2 Load in line mode**

Specification	Value	Unit
Input voltage curve	Sine wave	-
Input voltage	230	Vac
Maximum AC input voltage	250	Vac
Input frequency	50/60	Hz

**4.3 Load in battery mode**

Specification	Value	Unit
Output power	3,6	KVA/kW
Output voltage curve	Pure sine wave	-
Output voltage	230 ± 5%	Vac
Output frequency	50	Hz
Efficiency	95	%
Overload protection	120s @ 110-150% Power 30s @ 150-175% Power 10s @ 175-200% Power 5s @ 200-300% Power	-

**4.4 Charging**

Specification	Value	Unit
<b>Battery</b>		
Battery voltage	40	Vdc
Overcharge cut-off point	47,3	Vdc
<b>Line mode</b>		
Maximum input voltage	250	Vac
Maximum input current AC IN	16	A
<b>Solar mode</b>		
Maximum input voltage	160	Vdc
Maximum input current AC IN	15	A
Maximum charging current	1600	W

## 4.5 Information of battery cells and battery

Specification	Value	Unit
Cell type	Nickel-Manganese-Cobalt Accumulator (NMC)	-
Cell voltage	3,65	V DC
Cell capacity	54	Ah
Battery voltage	40	V DC
Battery capacity	2168	Wh

## 4.6 Connections

Connections	Output	Input
	1x 230V AC	1x 230V AC
1x USB-C	1x Photovoltaic	
	1x DC-IN (Expansion Plug)	

## 4.7 Operating conditions

### Working zone

Specification	Value	Unit
Ambient temperature when working	-18...60	°C
Storage temperature	-18...40	°C
Battery temperature at the start of charging	0...40	°C
Relative air humidity, maximum	15 – 75 (without condensing)	%
Conditions	Avoid direct impact of dampness, dust and frost. Do not operate in strong electric and magnetic fields! Do not operate the machine tool in explosive atmosphere!	

## 4.8 Type plate

The type plate is placed on the housing of the battery.

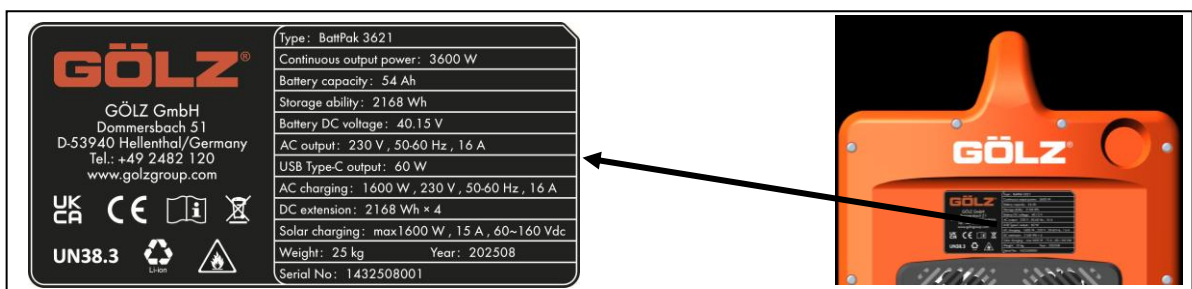

## 4.9 Installation site requirements

The floor surface must:

- ▶ have sufficient load bearing capacity,
- ▶ be slip proof,
- ▶ be level.

### **Installation conditions**

Choose the installation site as per space requirements according to the technical data.

## 4.10 Storage requirements

### **Storage conditions**

As a matter of principle, the BattPak, its components, assemblies or parts must be only stored in the following conditions:

- ▶ do not store outdoors
- ▶ store in dry and dust-free place
- ▶ do not expose to aggressive media
- ▶ protect from solar radiation
- ▶ avoid mechanical vibrations
- ▶ storage temperature range -18 to 40°C
- ▶ relative air humidity: max. 75%.
- ▶ Store the BattPak out of the reach of children and unauthorized persons.
- ▶ Do not store the BattPak in the discharged state for long periods of time. This could lead to deep discharge. Charge the BattPak at least once every three months.
- ▶ If stored for more than 2 months, regularly check the general condition of all parts and packaging. Also check the state of charge of the batteries. If necessary, refresh or renew the preservation and load the Battpak (at least 80%).
- ▶ Store the BattPak only when it is switched off.
- ▶ Store the BattPak separately from the electrical device and the charging cable.
- ▶ The charging cable is not intended to carry or hang the BattPak from it. The charging cable and the BattPak may be damaged.
- ▶ Coil the charging cable into a loop and secure it.

## 5 Design and function

This product is a 2168Wh energy portable two-way energy storage power product; suitable for family emergency power outages, outdoor travel, emergency rescue, fieldwork, and other occasions.

The product has a built-in semi-solid lithium ternary battery, supports AC direct charging and PV solar panel charging, AC direct charging power up to 1600W, and PV solar panel charging power up to 1600W.

230Vac/50Hz/60Hz AC sine wave AC output; DC output Type-C output interface can be used for a variety of lamps, fans, small cell phones tablet computers, and other devices. And tablet PCs, etc. It supports simultaneous charging and discharging and has

It supports charging and discharging at the same time, and has the functions of WIFI connection and APP to see the relevant data.

### 5.1 Scope of delivery and responsibility

The BattPak was developed and manufactured under sole responsibility of Gözl GmbH.

Upon transfer to the operator, the responsibility for safe handling and instruction of the personnel passes to the operator.

The manufacturer offers training on the BattPak.

The scope of delivery includes the following components:

Components	Quantity
BattPak 3621	1
Technical documentation	1
AC- charging cable	1
PV- charging cable	1
IP67- USB-C Discharge cable	1

### 5.2 BattPak 3621





**LCD Layout**

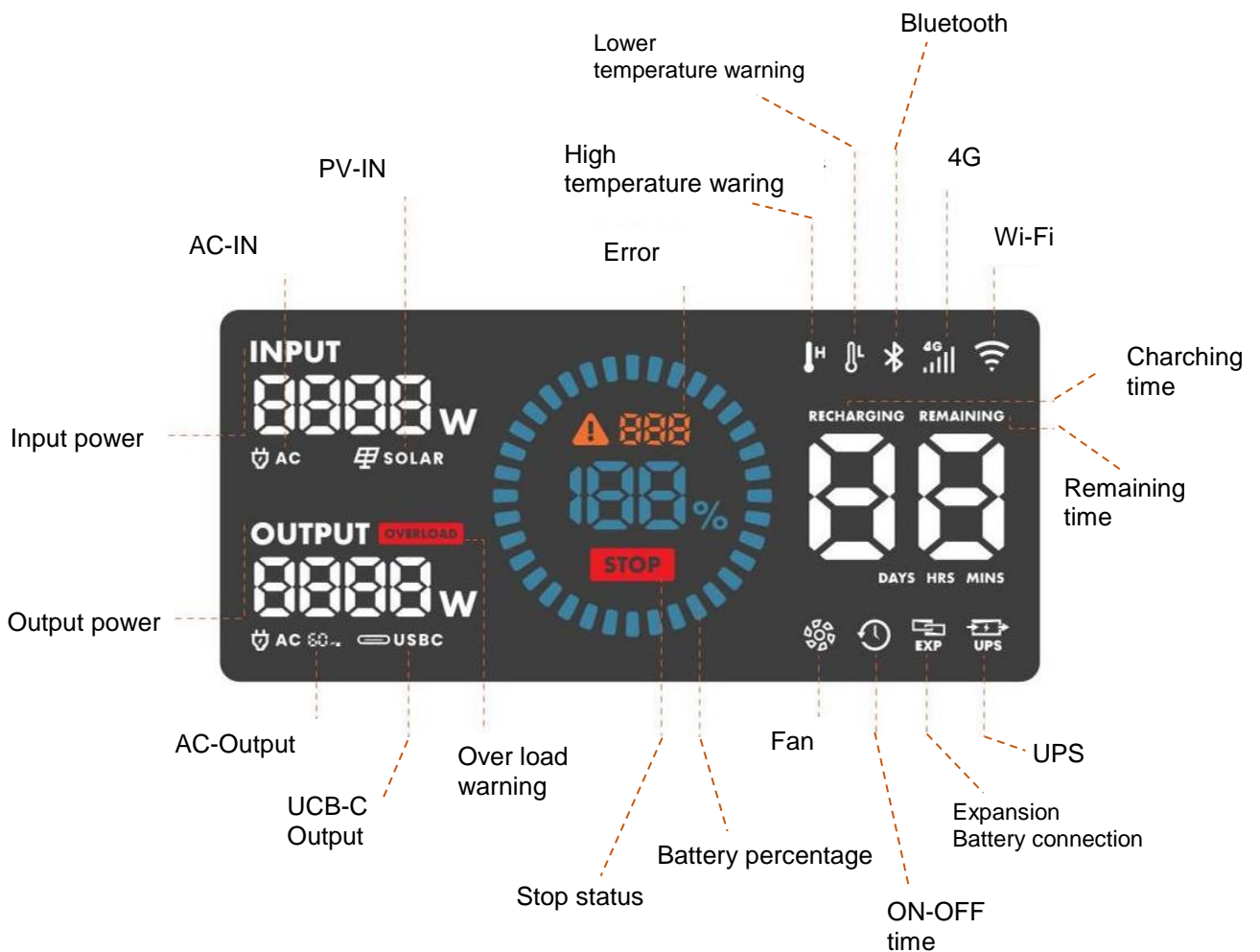

**Housing**

The housing (1) protects the electronics and the battery from physical and environmental influences.

**Plugs**

The various connectors of the battery are used to connect devices to the battery for operation, to charge the battery and to connect the battery to a battery extension.

**Battery**

The battery cells are made of semi-solid lithium ternary battery and are enclosed in an impact-resistant housing. They are used to supply power to the connected devices.

**Display**

The battery display shows all relevant info about the battery via LCD display.

**ON/OFF Switch**

The ON/OFF switch is used to turn the BattPak on or off.

**Fans**

The fans cool the BattPak and protect it from overheating.

**NOTE!**

*Due to the design, the emergency stop switch is located to the right of the battery indicator. A blow on the emergency stop causes the immediate interruption of the power supply to the connected devices.*

**5.2.1 Functional description**

By switching on the battery via the on-off switch, the power supply is released up to the terminals on the outside of the battery housing.

Now up can be operated in via the 230V socket of the battery.

All relevant information about the battery is shown on the LCD display on the front.

## 6 Transport & packaging

### 6.1 Transport safety information



**ATTENTION!**  
**Damage through improper transportation!**

Improper transportation can result in considerable damage of the transported goods and objects in the vicinity.

- Always proceed with the utmost care and caution when loading and unloading and transporting goods within the company.
- Pay attention to the instructions and symbols on the packaging.
- Always remove transport locks only during installation.
- Transport the appliance only when it is switched off.

**Observe your local transport regulations for batteries!**

### 6.2 Transport inspection

Inspect the condition of the transported goods immediately upon delivery for completeness and damage.

In the event of externally recognisable damages:

- ▶ do not accept the delivery or accept it only conditionally,
- ▶ record the scope of the damage in the transport documents and indicate it in the carrier's consignment note,
- ▶ lodge complaint.



**NOTE!**

*Claim any defect immediately upon delivery of the transported goods!  
 Claims regarding transport damage can only be lodged within valid complaint periods.*

### 6.3 Transport symbols

On the outside of the transported goods, there are symbols corresponding to the content, which must be strictly observed during transportation and storage.

**Meaning of the transport symbols**

The following transport symbols can be placed on the transported goods:

	<p><b>This side up</b></p> <p>The arrowheads indicate the top end of the transported goods. These should point upwards otherwise the content can be damaged.</p>		<p><b>Keep dry</b></p> <p>Protect the transported goods from dampness and keep them dry.</p>
	<p><b>Anchor point</b></p> <p>Only attach lifting tackle to the indicated points.</p>		<p><b>Centre of gravity</b></p> <p>Indicates the centre of gravity of the transported goods. Pay attention to the centre of gravity position when handling the goods!</p>

## 6.4 Transport and storage

### Handling packaging

The BattPak is packed in a safe and environmentally sound manner for the anticipated transport conditions. The packaging protects the parts up to the beginning of assembly from damage and corrosion.

- ▶ Only remove packaging and transport locks before assembly.
- ▶ Dispose of packaging materials according to applicable local regulations.



#### **ATTENTION!** **Environmental damage through improper disposal!**

Packaging material is valuable raw material and can be used again or expediently reprocessed and recycled.

- Always dispose of packaging materials in an environmentally sound manner.
- Follow local regulations. If necessary, employ a specialised company for waste disposal.

### Transport of the BattPaks



#### **ATTENTION!** **Damage through improper transportation!**

Improper transportation can result in considerable damage of the BattPak and objects in the vicinity.

Before every transport:

- protect from excessive shock, vibration, rain and sunlight
- transport with special care, do not throw, do not squeeze and do not place objects on the battpak

The BattPak can be transported by one person using the transport handles.



#### **NOTE!**

*The BattPak is not designed for crane transport. There are no appropriate load suspension points on the BattPak.*

- ▶ Observe your local transport regulations for batteries.
- ▶ Batteries may not be sent by post. Contact a shipping company if you want to ship undamaged batteries.
- ▶ Inspect the BattPak for damage before each use, as well as before and after prolonged transport.
- ▶ The BattPak may not be transported on a passenger aircraft. If necessary, contact the airline.
- ▶ Do not transport a damaged BattPak.
- ▶ During transport, the BattPak may tip over or shift. This can result in personal injury and property damage.
- ▶ Secure the BattPak with tension straps, a belt, or a net to prevent it from moving.
- ▶ If the Battpak is packaged:  
Pack the BattPak in such a way that it cannot move inside the packaging.

### Storage of the BattPak

Store the product in the following conditions:

- ▶ indoors only,

- ▶ store in dry and dust-free place,
- ▶ do not expose to aggressive media,
- ▶ protect from solar radiation,
- ▶ avoid mechanical vibrations,
- ▶ storage temperature: -18 to 40 °C,
- ▶ relative air humidity: max. 75%.
- ▶ Store the BattPak out of the reach of children and unauthorized persons.
- ▶ Do not store the BattPak in the discharged state for long periods of time. This could lead to deep discharge. Charge the BattPak at least once every three months.
- ▶ If stored for more than 2 months, regularly check the general condition of all parts and packaging. Also check the state of charge of the batteries. If necessary, refresh or renew the preservation and load the Battpak (at least 80%).
- ▶ Store the BattPak only when it is switched off.
- ▶ Store the BattPak separately from the electrical device and the charging cable.
- ▶ The charging cable is not designed to carry or hang the BattPak. The charging cable and the BattPak may be damaged.
- ▶ Wind up the charging cable in a loop and secure it.

## 7 Installation and first commissioning

### 7.1 Location

Place the BattPak in a suitable place. Check the safe stand before commissioning.

### 7.2 First commissioning and acceptance, general



#### **DANGER!**

**Risk of injury during the first commissioning. Therefore:**

- Before connecting consumers to the battery, make sure that they are switched off.
- Make sure that the BattPak is not placed on slopes or construction pits
- Make sure the surface is even
- Ensure sufficient lighting
- Keep environment clean and free from objects and cables
- Make sure, there are no unauthorised persons in the vicinity of the BattPak



The Battpak is delivered immediately ready for use.



#### **DANGER!**

**Danger to life due to electric current!**

**Failure to follow these instructions may result in a fatal electric shock!**

- If more than one consumer is connected at the same time, residual current protection must be ensured. This can be done by means of the PRCD adapter cable in front of each additional consumer, or using the PRCD built into the connection cable of the plugged-in machine.

## 8 Operation

### 8.1 Operation safety information



**WARNING!**

**Risk of injury due to improper operation!**

Improper operation may lead to heavy injuries.

- The product may only be operated by trained personnel authorised by the operator.
- Before every work, make sure that the safety devices are correctly installed and function without flaws.
- Never disable safety devices.
- Always keep the working zone tidy and clean! Objects, parts, workpieces, tools and cleaning devices loosely lying around are accident sources.



**DANGER!**

**Danger to life from electric current!**

Touching live parts leads to death. Damaged insulation or individual parts can be life-threatening.

- In case of defective electric components switch off immediately and arrange for repairs.
- Keep humidity away from live parts.

**Personnel**

- ▶ Instructed Personnel

#### 8.1.1 Power Distributor

The BattPak 3621 is designed to operate only one load (IT network at OUTPUT).

If you want to operate more than one load with the battery storage unit, the BP3621 power distributor must be used.

The power distributor allows operation of up to three loads simultaneously (one load per socket).

Each individual socket of the power distributor is protected by a 30mA RCD, ensuring personal protection in an IT network.

This is available as an accessory under article number 02885001115.



### 8.2 Start-up preparation

To safely use the product as intended, the following preconditions must be met:

- ▶ the machine stands firmly
- ▶ the machine has been checked for damage, loose screw connections and integrity
- ▶ The BattPak is fully charged

- ▶ The BattPak is cleaned
- ▶ If these steps cannot be completed:  
Do not use the BattPak. Contact GÖLZ® Service.

## 8.3 Power switch

Press Power Button, the indicator light around the button goes on. In 5s, the LCD screen lights and the system is powered on.

USB output port and AC output port are ready for output.

In this state bluetooth and WIFI network can be setup, later on they will be automatically connected; Bluetooth and WIFI need to be setup again when network changed.

Press Power Button, the indicator light around the button goes out. In 5s, the LCD screen goes off.

The system will power down. USB output port and AC output port will be turned off, and the whole machine will be in low power consumption mode.



**NOTE!**  
Wait until the system has booted.  
Then connect the selected device with a power  $\leq 3,6kW$ .



**WARNING!**  
**Be sure to keep the following things in mind!**  
Failure to observe the following points can cause significant damage to the battery.

- Before using the battery for the first time, be sure to charge it to 100%!
- Wait until the system has booted, only then connect a device to the battery!

The manufacturer does not assume any warranty for damage caused by incorrect use and non-observance of these instructions!

## 8.4 Operation/charging via 230V



**NOTE!**  
Wait until the system has booted. Then connect the selected device with a power  $\leq 3,6kW$ .

### 8.4.1 AC- input

A socket marked "AC-In" is used to connect the mains connection for charging via 230V. Please use the AC charging cable included in the package, plug it directly into an AC wall outlet, and make sure the wall output voltage is 230V. GÖLZ is not responsible for any consequences resulting from failure to follow the instructions, including, but not limited to, charging with other AC charging cables.



**NOTE!**

*GÖLZ is not liable for any consequences resulting from failure to follow the instructions, in particular for charging with other AC charging cables.*



Max.1600 W charging



One sockets marked "AC-Out" are used to connect a machine/device that is to be operated with the battery. One devices can be operated in if the input power does not exceed 3,6 kW.



**DANGER!**

**Danger to life from electric current!**

Touching live parts leads to death. Damaged insulation or individual parts can be life-threatening.

- Before charging, make sure the charging cable is undamaged. - Make sure the protective caps on the PV-IN and DC-IN connectors are in good condition; there should be no contact with the PV-IN and DC-IN pins.
- In case of defective electric components switch off immediately and arrange for repairs.

### 8.4.2 AC-Output

Press the power button to turn on the machine. Power on indicator goes on, then AC output is ready. Press the power button again to turn off the AC output.

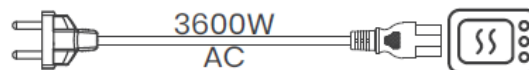

**NOTE!**

When connecting this BattPak to a refrigerator or other device that requires continuous power supply, please set the AC output to "Always On" in the App. If the BattPak is set to normal mode, the power supply may turn off automatically due to power fluctuations.

## 8.4.3 USB-Output

Press the Power button to turn on the BattPak, power-on indicator goes on, USB output is ready. Press the power button again to turn off the USB output.

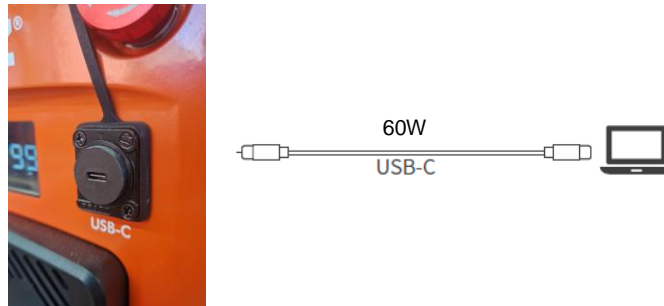

## 8.5 Charging via photovoltaics (PV)

Disconnect the AC-IN and turn off the BattPak before connecting the PV cable to the BattPak.

Check the cable connection between the PV component and the PV input terminal of the battery, then connect the positive terminal of the cable to the positive terminal of the PV input terminal of the device, and the negative terminal of the cable to the negative terminal of the PV input terminal of the device to ensure that the connection is firm and reliable.



**DANGER!**  
**Danger to life from electric current!**

Touching live parts leads to death. Damaged insulation or individual parts can be life-threatening.

- Before connecting the PV cable to the BattPak, make sure that AC-IN is disconnected.
- In case of defective electric components switch off immediately and arrange for repairs.



**NOTE!**

*Before connecting the PV modules to the battery, make sure that the maximum output power of the PV modules does not exceed the maximum charging power of the battery!*

### Selection of the PV component

When selecting a suitable PV component, the following parameters must be taken into account:

1. The voltage of the PV module must not exceed the maximum voltage of the PV charging port of the device.
2. The voltage of the PV module must be higher than the minimum battery voltage.

Max. power of the photovoltaic system	1600 W
Max. voltage of the photovoltaic system	160 Vdc
Max. current of the photovoltaic system	15 A
Photovoltaic system voltage range	60~160 Vdc

### 8.5.1 Charging via GÖLZ®- solar panel BL 400

- Using the 4x400W GÖLZ®- solar panels can charge the device to 80% in about 1,25 hours.
- When using GÖLZ®- solar panel to charge the BattPak, please follow the instructions that come with the solar panel.

- Before connecting the solar panel, please make sure the output voltage of the solar panel is within 200V to avoid damage to the BattPak.

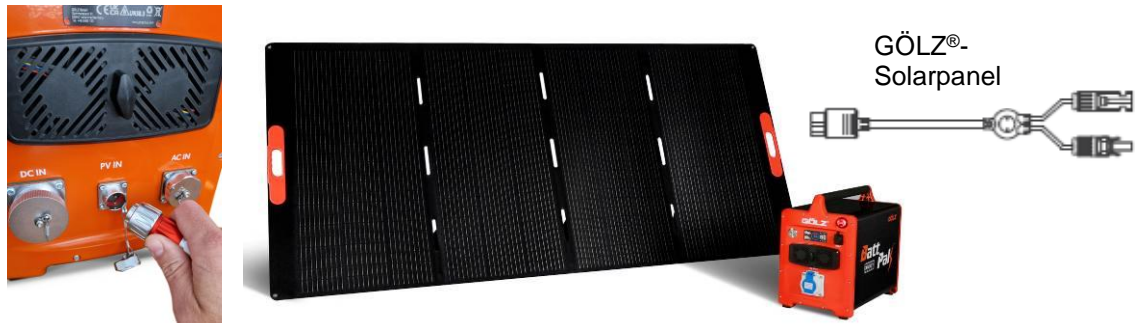

## 8.6 APP Connection

Press the Power button to turn on the BattPak, when the power on indicator goes on, you can start to set bluetooth and WIFI network, once it is set, later it can be automatically connected. Access to a new network need to be reset.



### 8.6.1 GÖLZ®-App

#### Download APP

##### Option 1:

Search for "BattPak" in the AppStore (for iOS) or Google Play (for Android) and download the GÖLZ app.



##### Option 2:

You can download the APP on the APPstore and Google Play by scanning the QR code below.









Google Play

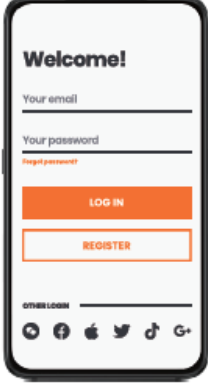

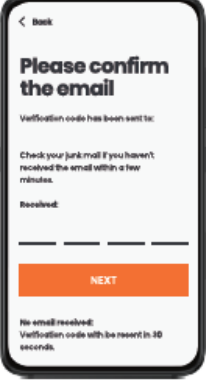

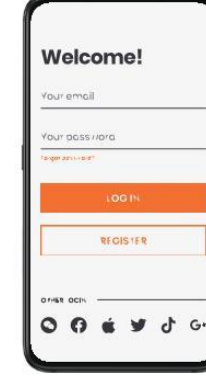

App Store

## Register

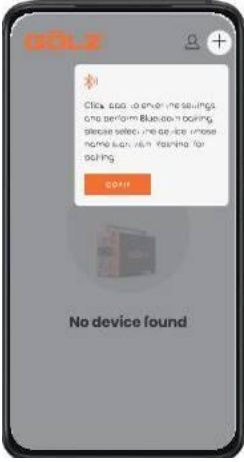
<p>1. Click the “BattPak” application and click “Register”.</p>	<p>2. Enter your e-mail address. After confirming the required information, check the “Agree” button and click “Next”</p>	<p>3. Checking the e-mail containing the verification code, enter the code.</p>
		
<p>4. Set your password and click “Next”.</p>	<p>5. After successfully registering, click “Back to Login” to return to the login screen</p>	<p>6. Enter your registration information and log in.</p>
		
<p>7. Turn on “Wi-Fi” and “Bluetooth” from the settings of your smartphone. Please note that if either of them is turned off, the connection is not available</p>		
		

## APP Connection

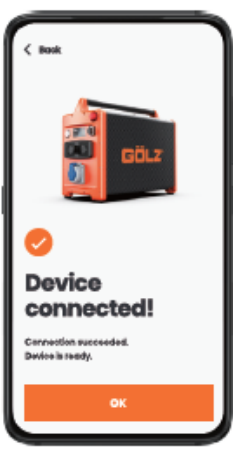
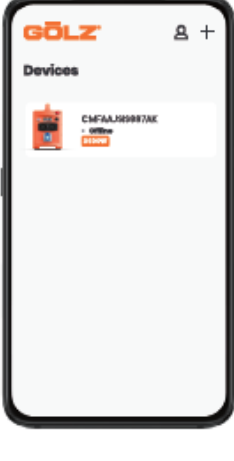
<p>1. Turn on the power. Once you see the icon (📶) in the upper right corner of the LCD screen blinking, go to the homepage of the application and click the “+” button on the upper right side of the application.</p>	<p>2. Select your device. If your application has been upgraded to the latest version, both Bluetooth and Wi-Fi connections are available. Select Bluetooth connection or Wi-Fi connection as required.. Click the “BattPak” application and click “Register”.</p>	<p>3. When you select Bluetooth connection, please make sure Bluetooth in your cell phone is turned on. If you select Wi-Fi connection, please enter your home Wi-Fi SSID and password, and then click “Start Connection”. Only support 2.4G Wi-Fi. Please note that 5G Wi-Fi cannot be connected.</p>
		
<p>4. Do not turn off the machine while it is connected</p> <p>*The LCD screen may turn off after 30 seconds during connection. Please wait for the connection.</p>	<p>5. When the connection is complete, click “OK”.</p>	<p>6. Select the device you connected from the home page of the application</p>
		

7. You can control your mobile battery power from this page in the application



## Firmware Update

1. Select the device to be updated from the home page.

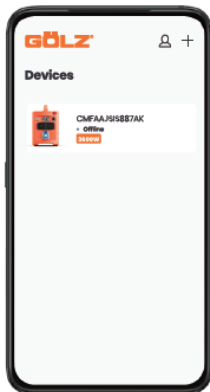

2. Click the Settings button in the upper right corner of the application.

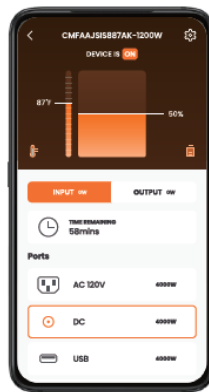

3. Select "Firmware" from the device settings

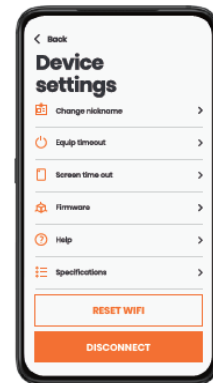

4. Click "Update".

\*Make sure that "Update" is displayed on the LCD screen of the portable station. After the update is completed, restart the application and try to connect to the application again.



## 8.7 UPS Function



**WARNING!**

**Risk of injury due to improper operation!**

Failure to observe the following point may result in serious injury or death and cause significant damage to the battery.

- Never connect more than one device to AC OUT (without further safety precautions)!

To use the UPS function, connect the BattPak to a power outlet using the AC charging cable, then press the button and connect your device via the AC output port.



- The BattPak supports off-grid type uninterruptible power supply. When you connect grid power to the AC input port of the BattPak via an AC cable, you can power your appliances via the AC output port. (In this case, the AC power comes from the grid, not from the mobile power).
- In the event of a sudden power failure, the BattPak can automatically switch to inverter mode within 20ms.
- As an off-grid UPS, this function does not support 0ms switching. Do not connect the BattPak to any equipment that requires a 0ms UPS, such as data servers and workstations.
- Please test and confirm compatibility before using the BattPak as an UPS.



**NOTE!**

*GÖLZ is not responsible for any equipment failure or data loss due to misuse of this BattPak.*

## 8.8 Expanded Battery Pack Xpansion 2100

Disconnect the AC-IN and turn off the device before connecting the BattPak Xpansion 2100.

The BattPak 3621 can be connected to the BattPak Xpansion 2100 via the DC connection cable. Detailed instructions can be found in the BattPak Xpansion 2100 user manual.

To extend the battery capacity, please follow the instructions below:



- Before connecting this BattPak 3621 to an BattPak Xpansion 2100, make sure both are turned off.

- ▶ After connecting, make sure no connection symbol is displayed on either LCD screen before use.
- ▶ Do not directly connect or disconnect the BattPak Xpansion 2100 during charging or discharging.
- ▶ Do not touch the metal contacts of the BattPak 3621 or BattPak Xpansion 2100 connectors with your hands or anything else. Clean them only with a soft, dry cloth if necessary.

## 9 Maintenance & cleaning

### 9.1 Maintenance safety information



**WARNING!**

**Risk of injury due to improper maintenance!**

Improper maintenance may lead to injuries.

- Any maintenance works must be only carried out by the service department of GÖLZ GmbH.
- Sufficient assembly freedom must be ensured before commencement of works.



**DANGER!**

**Danger to life from electric current!**

Touching live parts leads to death. Damage to the insulation or individual components can be life threatening.

- Before cleaning, switch off the battery and secure it against being switched on again, and also close the protective caps of the sockets.
- Keep moisture away from electrical components.

### 9.2 Maintenance plan

Maintenance works necessary for optimum and trouble-free operation are described in the following sections.

- ▶ If an increased wear of parts is revealed by regular inspections, reduce the maintenance intervals!
- ▶ Draw up a maintenance log after every maintenance! The log assists in error analysis, enables adjusting the intervals to actual usage conditions and validating guarantee claims.
- ▶ If you have any queries on maintenance works and intervals: contact manufacturer.

Interval	Maintenance work	Personnel
Before every commissioning	Visual inspection - the entire BattPak	Operating personnel
	Visual inspection - the electrical connections	Specialist personnel
After completion of work	Clean - Entire BattPak	Operating personnel
	Clean - Housing	Specialist personnel
yearly	Carry out a legal safety check in the case of - the entire BattPak	Qualified electricians
in case of an error	Visual inspection - the entire BattPak	Operating personnel
	Visual inspection - Connections	Specialist personnel

How should this BattPak be stored?

If the semi-solid-state battery mobile power supply is not used for a long period of time, please turn off the device and disconnect the AC adapter from the socket. Store the BattPak in a safe, dry place. Charge the BattPak to 80% every 3-6 months to protect the battery life.

## 9.3 Description of the maintenance works to be carried out by the operator



### **ATTENTION!**

Cleaning by a high-pressure cleaner will damage the product.

### **ATTENTION!**

Foaming and cleaning with water will damage the machine.

- Replacing the fan
- Clean electrical contacts with a brush or a soft bristle brush.

### 9.3.1 Fan Replacement



To replace the fan, loosen the wing screw located in the center of the fan housing. Then, the entire fan unit can be removed from the housing. When reinstalling the fan unit, make sure it is positioned correctly. Incorrect installation of the fan is prevented by the locking pin in the housing.

## 9.4 Steps after completing maintenance

After completion of the maintenance works and before switching on, follow the following steps:

1. Check for tightness all threaded joints previously detached.
2. Check the proper installation of all previously removed protective devices and covers.
3. Make sure that all tools, materials and other equipment have been removed from the working zone.
4. Clean the working zone and remove any spilled substances such as liquids, processing materials or similar.
5. Make sure that all safety devices of the system function properly.

## 10 Errors

### 10.1 Troubleshooting safety information



**WARNING!**  
**Risk of injury due to improper troubleshooting!**

Improper actions in the course of troubleshooting may lead to heavy injuries.

- Any repair works must be only carried out by the GÖLZ Service.
- Sufficient assembly freedom must be ensured before commencement of works.
- Always keep the working zone tidy and clean! Objects, parts, workpieces, tools and cleaning devices loosely lying around are accident sources.
- Check correct assembly of spare parts if these have been replaced. Fit properly all fastening elements. Observe screw tightening torques.
- Before recommissioning, make sure that all safety devices are properly installed and functional.



**WARNING!**  
**Risk of injury resulting from unauthorised restarting!**

When working on individual components, people can be injured due to unexpected switching on of the power supply of the connected devices.

- Before working on any individual parts, switch off the BattPak and secure it against being restarted.



**DANGER!**  
**Danger to life from electric current!**

Touching live parts leads to death. Damaged insulation or individual parts can be life-threatening.













- Switch off the battery before maintenance and repair operations and secure it against being restarted.
- Keep humidity away from live parts.

### 10.2 Actions in case of errors





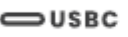











Basically, the following applies:









1. In the event of malfunctions that pose an immediate danger to persons or property, trigger emergency stops immediately.
2. Inform those responsible at the scene of the incident.
3. Depending on the type of malfunction, the cause should be determined and eliminated by responsible and authorized specialists.

## 10.3 Troubleshooting table

Error	Problems	Solutions
 AC 	High temperature protection for AC IN /PV IN	After the BattPak cools down, it will automatically resume normal operation.
 SOLAR 		
 AC 	High temperature protection for AC OUTPUT / USB-C	After the BattPak cools down, pressing the power button again, it will automatically restore normal operation.
 USBC 		
 AC 	Over-load protection for AC OUTPUT / USB-C	Remove the overloaded device, press the power button again, and it will automatically resume normal operation. Electrical appliances should be used within their rated power.
 USBC 		
	Machine fault warning	If a fault warning appears on the screen and does not disappear after restarting, please stop using it immediately and contact GÖLZ customer service.

## 10.4 Fault Code Summary Table

Code	Fault Event	Icon flashing	Icon/Status Prompt	Level/Remarks
1	Fan Locked	 001	-	Stall
2	Inverter Overheating	 002	High Temp Icon Steady On	-
3	Battery Overheating	 003	High Temp Icon Steady On	Level 1/2
4	Battery Undertemperature	 004	Low Temp Icon Steady On	Level 1/2
5	Output Overload	 005	OVERLOAD Icon Steady On	-
6	Output Short Circuit	 006	OVERLOAD Icon Steady On	-
7	Excessive Battery Pack Voltage Difference	 007	-	Level 1/2
8	Emergency Stop Fault	 008	-	Emergency Stop Button Pressed
9	Charging Overcurrent	 009	-	Level 1/2
10	AC Input Voltage Low	 010	AC Input Undervoltage	-
11	AC Input Voltage High	 011	AC Input Overvoltage	-
12	AC Input Frequency Low	 012	AC Input Underfrequency	-
13	AC Input Frequency High	 013	AC Input Overfrequency	-
14	PV Input Voltage Low	 014	PV Input Undervoltage	-
15	PV Input Voltage High	 015	PV Input Overvoltage	-
16	Type-C Output Overload/Short Circuit	 016	OVERLOAD Icon Steady On	-

Code	Fault Event	Icon flashing	Icon/Status Prompt	Level/Remarks
17	Bypass Fault	 017	UPS Icon Steady On	-
18	Expansion Pack Fault	 018	EXP Icon Steady On	-
19	BMS Communication Fault	 019	-	BMS-Main Control Communication Failure
20	INV Communication Fault	 020	-	INV-Main Control Communication Failure
21	IoT Module Communication Fault	 021	-	WiFi Module-Main Control Communication Failure
22	4G Module Fault	 022	-	4G Module Fault
80	Battery Pack Internal Fault	 080	-	-
81	Inverter Internal Fault	 081	-	-

## 10.5 Steps after troubleshooting

After completion of the troubleshooting and before switching on, follow the following steps:

1. Make sure that all tools, materials and other equipment have been removed from the working zone.
2. Clean the working zone and remove any spilled substances such as liquids, processing materials or similar.
3. Make sure that all safety devices of the machine function properly.

## 11 Disposal

After the design service life is over, the BattPak must be disposed of in an environmentally friendly manner.

In many countries, GÖLZ takes back your old appliance for recycling.

Unless a take-back or disposal agreement has been made, dismantled components shall be recycled:

- ▶ Scrap residual metallic components.
- ▶ Giving plastic parts for recycling.
- ▶ Dispose of remaining components sorted according to material properties.



### EU countries only

Electric waste is recyclable and must not be disposed of in the household waste!!

According to the European directive 2012/19/EU on electrical and electronic waste and version transposed into national law, used power tools must be collected separately and sent for recycling in an environmental-friendly manner.



### ATTENTION!

#### Environmental damage resulting from improper disposal!

Wrong or negligent disposal may result in significant environmental pollution.

- Electrical scrap, electronic components, lubricants, operating and other auxiliary materials must be disposed of by specialised companies.
- In case of hazardous substances, treatment and disposal provisions of the material safety data sheets must be taken into consideration.
- In case of doubts, consult the manufacturer or local municipal authorities or specialised disposal companies on the environmentally safe ways of disposal.

## 12 Index

### A

Accident.....	15
Acronyms.....	5

### C

Copyright.....	7
Customer service.....	7

### D

#### Danger

<b>electric current</b> .....	11
Illegible signs.....	16
<b>Download APP</b> .....	32

### E

<b>Electric current</b> .....	11
Electric waste.....	43
<b>EU conformity declaration</b> .....	45
Explanation of symbols.....	5

### G

General.....	5
--------------	---

### I

Installation conditions.....	20
Installation site requirements.....	20
Intended use.....	8

### L

Liability limitation.....	6
Location.....	27

### M

Maintenance plan.....	38
Maintenance safety information.....	38

### O

Operating manual.....	5
<b>Operation</b> .....	28

Operation safety information.....	28
-----------------------------------	----

### P

Packaging.....	25
Power Distributor.....	28

### Q

Qualification.....	9
Qualified electricians.....	9

### R

#### Risks

electrical hazards.....	11
-------------------------	----

### S

Safety.....	8
Scope of delivery and responsibility.....	21
Signage.....	16
Spare parts.....	15
Start-up preparation.....	28
<b>Storage conditions</b> .....	20
Storage requirements.....	20
Symbols.....	5

### T

Terminology.....	5
<b>Transport</b> .....	24
Transport inspection.....	24
Transport safety information.....	24
Transport symbols.....	24
Troubleshooting safety information.....	40
Troubleshooting table.....	41
Type plate.....	19

### U

UPS Function.....	36
-------------------	----

### W

Warranty.....	7
<b>Warranty coverage</b> .....	7
Wear parts.....	7

**EU conformity declaration**

**GÖLZ® GmbH**  
 Dommersbach 51  
 D-53940 Hellenthal  
 Germany

declares under sole responsibility that

<b>Model:</b>	<b>Energiesystem</b>
<b>Manufacturer:</b>	<b>GÖLZ</b>
<b>Type:</b>	<b>BattPak 3621</b>

comply with the relevant provisions of the Directives

<b>2014/30/EU</b>	<b>2011/65/EU</b>
<b>2014/35/EU</b>	<b>EU 2015/863:2015-03-31</b>
<b>2012/19/EU</b>	<b>EUV 2023/1542:2023-07-12</b>
<b>UN38.3</b>	

and has been developed and fabricated in compliance with the following standards valid as at the production date:

<b>DIN EN 62133-2:2022-12; VDE 0510-82:2022-12</b>	<b>DIN EN 50663:2019-04; VDE 0848-663:2019-04</b>
<b>DIN EN IEC 62619:2023-08; VDE 0510-39:2023-08</b>	<b>DIN EN 50665:2019-05; VDE 0848-665:2019-05</b>
<b>DIN EN 62109-1:2011-04; VDE 0126-14-1:2011-04</b> <b>DIN EN 62109-2:2012-04; VDE 0126-14-2:2012-04</b> <b>DIN EN IEC 62109-3:2024-09; VDE 0126-14-3:2024-09</b>	<b>DIN EN IEC 55015:2020-07; VDE 0875-15-1:2020-07</b>
<b>DIN EN IEC 62040-3:2022-10; VDE 0558-530:2022-10</b>	<b>DIN EN IEC 61547:2023-11; VDE 0875-15-2:2023-11</b>
<b>DIN EN 61000-4-2:2009-12; VDE 0847-4-2:2009-12</b>	<b>DIN EN 55032:2022-08; VDE 0878-32:2022-08</b>
<b>DIN EN IEC 61000-6-3:2022-06; VDE 0839-6-3:2022-06</b> <b>DIN EN IEC 61000-6-1:2019-11; VDE 0839-6-1:2019-11</b>	<b>DIN EN 55035:2018-04; VDE 0878-35:2018-04</b>
<b>DIN EN 301489-2:2019-11</b>	<b>DIN EN 300328:2019-10</b>
<b>DIN EN IEC 62368-1:2025-01; VDE 0868-1:2025-01</b>	<b>DIN EN IEC 62477-1:2024-09; VDE 0558-477-1:2024-09</b>
<b>DIN EN IEC 60730-1:2021-03; VDE 0631-1:2021-03</b>	<b>DIN EN 62321-3-1:2014-10; VDE 0042-1-3-1:2014-10</b>
<b>DIN EN 18031-1:2025-05</b>	<b>DIN EN 18031-2:2025-03</b>

Technical documentation kept by:

**GÖLZ® GmbH**  
 Development and design

Year of construction and machine number are indicated on the unit.

Hellenthal, 10/12/2025  
 GÖLZ® GmbH

  
 Managing Director