

# Translation of the Original Operating Manual

## Bridge Saw – GS 350A-120



**Read operating manual before starting any work!  
Keep the operating manual for future use!**

Revision			
Date	Chapter	Reason of change	Person responsible
03-19		Recreation	Design
02-21	12.4.2	Wheel set changed	Design

Revision status: 2021-02  
Serial number:

© Gölz GmbH  
Dommersbach 51  
D- 53940 Hellenthal

Tel.: +49 (0)2482 – 12 200  
Fax: +49 (0)2482 – 12 222

E-Mail: [info@goelz.de](mailto:info@goelz.de)  
Internet: [www.goelz.de](http://www.goelz.de)

# 1 Content

<b>1</b>	<b>Content</b>	<b>4</b>
<b>2</b>	<b>General information</b>	<b>5</b>
2.1	Operating manual	5
2.2	Symbols, abbreviations, terms	5
2.3	Explanation of symbols	5
2.4	Limitation of liability	6
2.5	Customer Service	7
2.6	Copyright	7
<b>3</b>	<b>Safety</b>	<b>8</b>
3.1	Appropriate use	8
3.2	Reasonably foreseeable misuse	8
3.3	Responsibility of the operator	9
3.4	Responsibility of the staff	10
3.5	Personnel requirements	10
3.6	Personal protective equipment	11
3.7	Dangers	11
3.7.1	Risks from mechanical hazards	11
	<b>Flying cut material / tool</b>	<b>12</b>
3.7.2	Risks from electrical hazards	12
3.7.3	Risks from thermal hazards	12
3.7.4	Risks due to specific physical agents	13
3.7.5	Risks from hazardous substances	13
3.7.6	Risks from working environment conditions	13
3.8	Safety devices	13
3.9	Spare parts	14
3.10	Conduct in case of danger and accidents	14
3.11	Signage	15
<b>4</b>	<b>Technical data</b>	<b>17</b>
4.1	Dimension machine	17
4.2	Dimensions of cut material	17
4.3	Connection and motor values	17
4.4	Other data	17
4.5	Water pump	17
4.6	Noise emissions	18
4.7	Operating conditions	19
4.8	Cutting blades	19
4.9	Type plate	20
4.10	Requirements for the installation site	20
4.11	Storage requirements	20
<b>5</b>	<b>Design and function</b>	<b>21</b>
5.1	Scope of delivery and responsibilities	21
5.2	GS 350A-120	22
5.2.1	Functional description	23
<b>6</b>	<b>Transport &amp; Packaging</b>	<b>24</b>
6.1	Safety instructions for transport	24
6.2	Transport Inspection	24
6.3	Transport symbols	24
6.4	Transportation and storage	25
<b>7</b>	<b>Installation and initial commissioning</b>	<b>27</b>
7.1	Safety Instructions for Installation	27
7.2	Setting up	27

7.3	Connect.....	28
7.4	Initial commissioning and acceptance, general .....	28
7.4.1	Measures before initial commissioning .....	29
7.4.1.1	Mounting the cut-off wheel .....	29
7.4.1.2	Filling the water sump .....	29
<b>8</b>	<b>Operating.....</b>	<b>30</b>
8.1	Safety instructions for operation .....	30
8.2	Intended working position of the operator .....	30
8.3	Preparations for launch.....	31
8.4	Switch on .....	31
8.5	Cutting process .....	32
8.5.2	45°- bevel cuts .....	33
8.5.3	Water supply .....	34
8.6	Ending the cutting process .....	34
<b>9</b>	<b>Maintenance &amp; Cleaning .....</b>	<b>35</b>
9.1	Safety instructions for maintenance .....	35
9.2	Maintenance plan .....	35
9.3	Description of the maintenance work carried out by the operator .....	37
9.3.1	Changing the blade.....	37
9.3.2	Check the water connection .....	37
9.3.3	Water pump and water sump.....	37
9.4	Measures after maintenance .....	37
9.5	Note on components subject to wear and tear .....	37
<b>10</b>	<b>Faults .....</b>	<b>39</b>
10.1	Safety Instructions for Troubleshooting .....	39
10.2	Behaviour in case of disturbances.....	39
10.3	Fault table .....	40
10.4	Measures to be taken after the fault has been rectified .....	41
<b>11</b>	<b>Disassembly and disposal.....</b>	<b>42</b>
11.1	Safety instructions for disassembly and disposal .....	42
11.2	Disassembly.....	42
11.3	Disposal .....	42
<b>13</b>	<b>Wiring diagram.....</b>	<b>46</b>
	<b>EU conformity declaration .....</b>	<b>47</b>

## 2 General information

### 2.1 Operating manual

These operating instructions provide all the information required for safe and efficient handling of the machine and form the basis for all actions performed on it. It is an integral part of the machine and must be kept in its immediate vicinity and accessible at all times to the personnel working on it.

A prerequisite for safe working on the machine is that all specified safety instructions and instructions for action are observed. The personnel must therefore have carefully read and understood this operating manual before starting any work.

In addition, the local accident prevention regulations and general safety regulations applicable at the place of use of the machine must be observed

### 2.2 Symbols, abbreviations, terms

This document uses signs, abbreviations and technical terms with the following meaning:

- ▶ See under
- Enumeration
- 1 Position number
- 1. Action step
- Text in italics* Comments on facts
-  Refers to a document contained in the documentation supplied. The place where the document was found is indicated in italics after the symbol.

### 2.3 Explanation of symbols

#### Warnings and safety instructions

Warnings and safety instructions in the manual are marked by pictograms and highlighted in a grey highlighted block.

Warning and safety instructions that draw attention to fundamental dangers are additionally introduced with signal words that express the extent of damage. These are structured as follows:

**SIGNAL WORD!**  
**Origin of the danger!**  
Consequences if the danger is not observed.  
- Code of conduct to avoid the danger

- ▶ Observe all warnings and safety instructions!
- ▶ Always act with caution when working to avoid accidents, personal injury and damage to property!

The pictograms in connection with the signal words mean



#### **DANGER!**

... indicates an imminent danger that will result in death or serious injury if not avoided.



#### **WARNING!**

... indicates a potentially hazardous situation which, if not avoided, could result in death or serious injury.



## CAUTION!

... indicates a potentially hazardous situation which, if not avoided, may result in minor injuries.



## ATTENTION!

... indicates a potentially hazardous situation which may result in damage to property if not avoided.

## Tips and recommendations



## NOTE!

... highlights tips, recommendations and information for efficient and trouble-free operation.

## Special safety instructions

To point out special dangers, the following pictograms are used in conjunction with safety instructions:



... indicates hazards due to electric current.  
Non-observance of the safety instructions may result in serious or fatal injuries.



... indicates danger of crushing.  
If the safety instructions are not observed, there is a risk of serious injury on moving parts.



... indicates hazards from hot surfaces.  
If the safety instructions are not observed, there is a risk of burns and serious skin injuries due to heat.



... indicates hazards due to rotating cut-off wheels.  
If the safety instructions are not observed, there is a risk of cuts and serious skin injuries from rotating cutting discs.

## 2.4 Limitation of liability

All information and notes in these instructions have been compiled taking into account applicable standards and regulations, the state of the art and our many years of knowledge and experience.

The manufacturer assumes no liability for damages due to:

- ▶ Non-compliance with the instructions
- ▶ Unintended use
- ▶ Use of untrained and uninformed personnel
- ▶ Arbitrary conversions
- ▶ Technical changes
- ▶ Use of non-approved spare parts

The obligations agreed in the supply contract, the General Terms and Conditions of Business as well as the manufacturer's terms of delivery and the legal regulations valid at the time of conclusion of the contract shall apply.

## Warranty

The manufacturer guarantees the functionality of the applied process technology and the stated performance parameters.

The warranty period begins with the defect-free handover.

## Wearing parts

Wearing parts are all components that are in direct contact with the material to be treated or processed during proper operation. These components are excluded from warranty and defect claims, as far as they are operational wear and tear.

## Service life guarantee

A service life guarantee is given for wear parts for a period of 6 months after acceptance without defects.

## Warranty conditions

12 months after delivery on mechanical and electrical components for single-shift operation, excluding wear parts and tools.

The warranty claim expires if the system is not installed and started up by our specialists.

The warranty extends to the parts to be replaced. Consequential damages are excluded.

Also excluded are damages caused by natural wear and tear, defective or improper maintenance, disregard of operating instructions, excessive strain and use of unsuitable equipment.

## 2.5 Customer Service

Our customer service is available for technical information.

**Service-Hotline**  
**02482 – 12 200**

Information about the regionally responsible contact person can be obtained by telephone and is available at any time by fax, e-mail or via the Internet.

In addition, our employees are always interested in new information and experience that results from the application and can be valuable for the improvement of our products.

## 2.6 Copyright

This document is protected by copyright. Unauthorized transfer of the manual to third parties, duplication in any form or manner, even in part, as well as the use and/or communication of the contents are not permitted without the written permission of the publisher.

Contraventions obligate to compensation for damages. Further claims are reserved.

### 3 Safety

This section provides an overview of all safety aspects for the protection of the operator and user from possible dangers and the safe and trouble-free operation of the system. Non-observance of the listed instructions, warnings and safety instructions can result in considerable dangers.

#### 3.1 Appropriate use

The bridge saw GS350A-120 is intended exclusively for the following commercial use:

##### **The Bridgesaw GS350A-120**

- is designed for wet cutting of solid building materials, such as clinker, bricks, concrete products, refractory, natural and artificial stone products, tiles and ceramics.



##### **WARNING! Danger due to improper use!**

Any use of the machine other than the intended use can lead to dangerous situations.

- Only use the machine for its intended purpose in accordance with the information in this document, in particular in compliance with the application limits specified in the technical data.
- Do not use the machine for any other purpose or in any other way.
- Do not modify, convert or change the design or individual parts of the equipment with the aim of changing the area of application or the usability of the machine.

- ▶ Claims of any kind for damage resulting from improper use are excluded.
- ▶ The operator alone is liable for all damage caused by improper use.

#### 3.2 Reasonably foreseeable misuse



##### **WARNING! Risk of injury through misuse!**

Misuse of the machine can lead to dangerous situations for persons and cause serious damage to property.

- Do not misuse the machine.

Any use of the machine beyond its intended use is considered improper and is prohibited.

This applies in particular to:

- the separation of non-approved building materials, e.g. wood, metal, plastic
- the separation of any materials other than those listed
- cutting without or with opened cut-off wheel protective cover
- cutting without water
- cutting of the material to be cut using the pendulum cutting method (vertical immersion from above into the material to be cut)

## 3.3 Responsibility of the operator

### Operator

The operator is any natural or legal person who uses the machine or allows third parties to use it and is responsible for the safety of the user, personnel or third parties during use.

### Obligations of the operator

The machine is used in the commercial sector. The operator of the machine is therefore subject to the legal obligations for occupational safety.

In addition to the warning and safety instructions in this manual, the safety, accident prevention and environmental protection regulations valid for the area of application of the machine must be observed.

#### **In particular, the operator must:**

- ▶ inform themselves about the applicable occupational health and safety regulations.
- ▶ identify possible additional hazards through a risk assessment, which are special application conditions at the place of use of the machine.
- ▶ operating instructions implement the necessary behaviour requirements for the operation of the machine at the place of use.
- ▶ regularly check during the entire period of use of the machine whether the operating instructions issued by him correspond to the current status of the regulations.
- ▶ adapt the operating instructions, if necessary, to new regulations, standards and operating conditions
- ▶ clearly and unambiguously define the responsibilities for the installation, operation, maintenance and cleaning of the machine
- ▶ Ensure that all employees working on the machine have read and understood the operating instructions. In addition, he must train the personnel at regular intervals in the use of the machine and inform them about the possible dangers.
- ▶ provide the personnel responsible for working on the machine with the prescribed and recommended protective equipment

Furthermore, the operator is responsible for ensuring that the machine

- ▶ is always in a technically perfect condition.
- ▶ is maintained in accordance with the specified maintenance intervals.
- ▶ all safety devices of the machine are regularly checked for completeness and functionality.

### 3.4 Responsibility of the staff

The machine is in commercial use. The personnel is therefore subject to the legal obligations for occupational safety.

In addition to the warning and safety instructions in this manual, the safety, accident prevention and environmental protection regulations valid for the area of application must be observed.

In particular, the personnel:

- ▶ is informed about the applicable occupational health and safety regulations.
- ▶ complies with the behaviour requirements laid down in the operating instructions for the operation of the machine on site.
- ▶ properly carries out the assigned responsibilities for the operation, maintenance and cleaning of the machine
- ▶ must have read and understood the operating instructions completely before starting work.
- ▶ uses the prescribed and recommended protective equipment

Furthermore, each employee working on the machine is responsible, within his scope of responsibility, for ensuring that the machine

- ▶ is always in technically perfect condition.
- ▶ is maintained according to specified maintenance intervals.
- ▶ all safety devices are regularly checked for completeness and functionality.

### 3.5 Personnel requirements

#### Basic information

Any work on the machine may only be carried out by persons who are able to carry out their work properly and reliably and who comply with the respective specified requirements.

- ▶ Persons whose reactions are affected, e.g. by drugs, alcohol or medication, must not carry out any work.
- ▶ When employing personnel, always observe the age and occupation-specific regulations applicable at the place of use.

#### Qualification



#### **WARNING!** **Risk of injury due to insufficient qualification!**

Improper work can lead to considerable personal injury and damage to property.

- All activities may only be performed by persons who have the necessary training, knowledge and experience.

#### Instructed personnel

Instructed personnel are persons who have been informed in detail and verifiably by the operator about the tasks assigned to them and possible dangers.

#### Technical staff

Qualified personnel are deemed to be those who, on the basis of their professional training, knowledge and experience as well as knowledge of the relevant regulations, are able to carry out the assigned work properly, recognise possible dangers independently and avoid personal injury or damage to property.

#### Qualified electrical personnel

All work on the electrical equipment may only be carried out by qualified electricians.

Qualified electricians are persons who, due to their technical training, knowledge and experience as well as their knowledge of the relevant regulations, are able to carry out work on electrical equipment properly, to recognize possible dangers independently and to avoid personal injury and damage to property caused by electric current.

## Unauthorized persons



### **WARNING!** **Risk of injury to unauthorised persons!**

Non-instructed persons are not aware of the dangers in the work area and are considered to be unauthorized.

- Keep unauthorised persons away from the work area, in case of doubt contact the persons concerned and show them to leave the work area.
- Interrupt work while unauthorized persons are in the work area.

## 3.6 Personal protective equipment

Personal protective equipment must be worn during work.

- (1) Helmet with hearing protection
- (2) Visor or safety goggles
- (3) Dust protection / breathing mask
- (4) Safety gloves
- (5) Suitable protective clothing
- (6) Safety shoes with protective cap

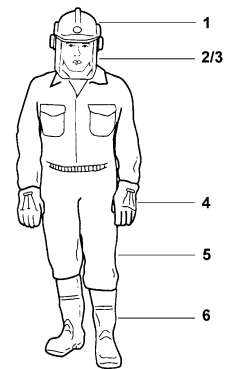

### **NOTE!**

*Protective gloves must not be worn for rotating parts where there is a risk of being drawn in. Here the risk of wearing is clearly higher than the intended protective effect.*

## 3.7 Dangers

The machine has been subjected to a risk assessment. The hazards identified in this assessment have been eliminated as far as possible and any risks identified have been reduced. Nevertheless, the machine still poses residual risks, which are described in the following section.

- The warning and safety instructions given here and in the chapters of this manual must be strictly observed to avoid possible damage to health and dangerous situations.

### 3.7.1. Risks from mechanical hazards

#### Rotating tools



### **CAUTION!** **Risk of injury through cuts!**

Reaching into rotating tools can lead to serious injuries.

- Never touch the rotating blade
- Never work without blade protection
- Only work with closed blade protective cover
- Remove cut material only when the cutting wheel is stationary

### Flying cut material / tool



**CAUTION!**  
**Risk of injury from pieces of cut material or tools flying around!**

Failure to wear suitable protective equipment, working with the cut-off wheel protective cover open or with unsuitable cut-off wheels can lead to serious injury.

- Wear protective goggles
- Only work with closed protective cover
- Only work with blades that are designed for the material to be cut

### Movable components



**CAUTION!**  
**Risk of injury from crushing moving parts!**

Failure to wear suitable protective equipment can lead to serious injury.

- Wear protective gloves
- Lock the cutting head
- Lock the guide bridge

### 3.7.2 Risks from electrical hazards

#### Electric current



**DANGER!**  
**Danger to life from electric current!**

Touching live parts leads to death. Damage to the insulation or individual components can be life-threatening.

- Before starting any work on the electrical system, disconnect the machine from the power supply. Check that the machine is de-energised!
- Before maintenance, cleaning and repair work, switch off the electrical power supply and secure it against being switched on again.
- If the insulation is damaged, switch off the power supply immediately and arrange for repair.
- Do not bypass or disable fuses.
- When replacing defective fuses, always ensure that the current rating is correct.
- Keep moisture and humidity away from live parts.
- Any work on the electrical system may only be carried out by qualified electricians.

### 3.7.3 Risks from thermal hazards

#### Hot surfaces



**CAUTION!**  
**Risk of burns from hot surfaces!**

Contact with hot components can cause burns.

- Do not touch surface
- Before all work, ensure that the components have cooled down to ambient temperature.

## 3.7.4 Risks due to specific physical agents



### **CAUTION!**

#### **Risk of injury due to special physical effects!**

Failure to wear suitable protective equipment can lead to serious injury.

- Wear ear protection
- Wear safety gloves
- Observe appropriate breaks
- Regular medical check 'G20'

## 3.7.5 Risks from hazardous substances



### **CAUTION!**

#### **Risk of injury from hazardous substances such as dust and cutting water or cutting sludge!**

Failure to wear suitable protective equipment may result in damage to health.

- Use personal protective equipment
- Replace cutting water regularly
- Use a dust mask
- Switch on water supply

## 3.7.6 Risks from working environment conditions



### **CAUTION!**

#### **Risk of injury due to insufficient lighting.**

Working under inadequate lighting can lead to serious injury.

- Ensure adequate lighting at the workplace

## 3.8 Safety devices



### **WARNING!**

#### **Danger to life due to defective or bypassed safety devices!**

Safety devices that are not functioning, bypassed or disabled do not protect against the dangers and can lead to serious injury or death.

- Always check that all safety devices are correctly installed and functional before starting work.
- Never override safety devices.
- Ensure that the safety devices are always freely accessible



### **NOTE!**

Location of the safety devices → "Design and function".

### 3.9 Spare parts



**WARNING!**  
**Risk of injury due to incorrect spare parts!**

Faulty spare parts can seriously impair safety and cause damage, malfunctions or even total failure.

- Only use original spare parts.

Original spare parts can be obtained from authorised dealers or directly from the manufacturer.

### 3.10 Conduct in case of danger and accidents

#### **Preventive measures**

- ▶ Always be prepared for accidents and fire.
- ▶ Keep first aid equipment (first aid kit, blankets, etc.) and fire extinguishers handy.
- ▶ Familiarise personnel with the accident reporting, first aid and rescue facilities.
- ▶ Always keep access routes for rescue vehicles clear.

#### **Acting correctly in the event of an emergency**

- ▶ Trigger emergency stop immediately
- ▶ initiate first aid measures
- ▶ Rescue affected persons from the danger zone.
- ▶ Inform the person responsible at the place of operation.
- ▶ In case of serious injury, alert the doctor and/or fire brigade.
- ▶ Keep access routes open for escape routes.

### Danger from electric current



**DANGER!**  
**Danger to life from electric current!**

Touching live parts leads to death. Damage to the insulation or individual components can be life-threatening.

- Before starting any work on the electrical system, disconnect the machine from the power supply. Check that the machine is voltage-free!
- Before maintenance, cleaning and repair work, switch off the electrical power supply and secure it against being switched on again.
- If the insulation is damaged, switch off the power supply immediately and arrange for repair.
- Do not bypass or disable fuses.
- When replacing defective fuses, always ensure that the current rating is correct.
- Keep moisture and humidity away from live parts.
- Any work on the electrical system may only be carried out by qualified electricians.
- annual inspection of the electrical system according to VDE0701

### Danger from cuts



**CAUTION!**  
**Risk of injury through cuts!**

Reaching into moving tools can lead to serious injuries.

- Never touch the rotating blade
- When changing the blade disconnect the machine from the power supply

## Illegible signage









### CAUTION! Risk of injury due to illegible symbols!

Stickers and signs that have become obscure no longer make danger spots sufficiently recognizable and cannot indicate possible injury hazards.

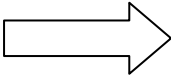
- Always keep pictograms, safety, warning and operating instructions in a clearly legible condition.
- Replace damaged or illegible pictograms, inscriptions, signs or stickers immediately.

The following symbols and information signs are located on the machine to draw attention to possible dangers:

	<p>Warning of rotating tool!</p>	
	<p>Direction of rotation of the saw blade</p>	
	<p>wear gloves wear hearing protection Machine complies with EU directive Observe operating instructions Wear protective goggles</p>	

## 4 Technical data

### 4.1 Dimension machine

Information	Value	Unit
Length	1500	mm
Width	640	mm
Height	1490	mm
Tare weight	113	kg
Operating Weight	145	kg

### 4.2 Dimensions of cut material

Information	Value	Unit
max. Length	1250	mm
max. Width	600	mm
Max. Height	100	mm
max. Weight	80	kg

### 4.3 Connection and motor values

Information	Value	Unit
Nominal voltage	110/230	V
Nominal frequency	50	Hz
Power	2,2	kW
Power consumption	20	A
Necessary protection	29	A
Cutting shaft speed	2800	U/min
Motor protection class	IP55	
Motor operating mode	S6	

### 4.4 Other data

Information	Value	Unit
Water sump	30	l
Cutting blade	350	mm
Bore	25,4	mm
Flange Ø	90	mm
Vibration value	2,3	m/s <sup>2</sup>

Measuring tolerance		
Vibration value	0,2	m/sec <sup>2</sup>

### 4.5 Water pump

Information	Value	Unit
Nominal voltage	110/230	V
Nominal frequency	50	Hz
Power	50	W
Operating mode	S2	

### 4.6 Noise emissions

	Without load	Full load
Sound pressure level	64 dB (A)	78 dB (A)
Sound power level	75 dB (A)	91 dB (A)

Measuring tolerances	
Sound pressure level	4 dB (A)
Sound power level	2,5 dB (A)

Guaranteed sound power level	80 dB (A)
------------------------------	-----------

The specification defines the volume of the noise pollution, in relation to the operator's workplace and the sound power level of the machine.

The emission values were carried out in accordance with the standards EN ISO 3744, EN 12418 and Directive 2005/88/EC.

## 4.7 Operating conditions

### Workspace

Angabe	Value	Unit
Temperature range	Room temperature 5-45	°C
Relative humidity, maximum	60 (without condensation)	%
Conditions	Only operate the machine in a dust-free environment! Avoid direct wetness, dust exposure and frost. Do not operate in strong electric and magnetic fields! Do not operate the machine in an explosive environment!	

## 4.8 Cutting blades

Cutting blade	Cutting blade diameter	Material	Number of segments	Segment height
SlimFast	Ø 350 mm	ceramic, fine stoneware, tiles, marble, granite	-	10 mm
RX1		concrete, exposed aggregate concrete, brick, clinker, hard stone, granite	24	16 mm
GN25		hard stone, granite, natural and artificial stone	24	10 mm



**DANGER!**  
**Risk of injury due to defective or incorrectly mounted blades!**

Wrong direction of rotation and damaged cut-off wheels can lead to serious personal injury!

- Before starting work, check cut-off wheels for breakage of individual segments, segment pieces, cracks at the segment foot, deformation of the cut-off wheel or wear.
- Observe direction of rotation arrows on the cut-off wheel and cut-off wheel protective cover!



**DANGER!**  
**Risk of injury from untested or approved tools!**

Untested or approved cutting discs or circular saw blades can cause serious personal injury!

- Check that the correct cut-off wheel is fitted before starting work.
- Observe direction of rotation arrows on the cut-off wheel and cut-off wheel protective cover!



**NOTE!**

All cut-off wheels used must be designed for the maximum drive speed of the machine and the intended use with regard to their permissible maximum cutting speed.

## 4.9 Type plate

The type plate is located on the base frame of the machine.

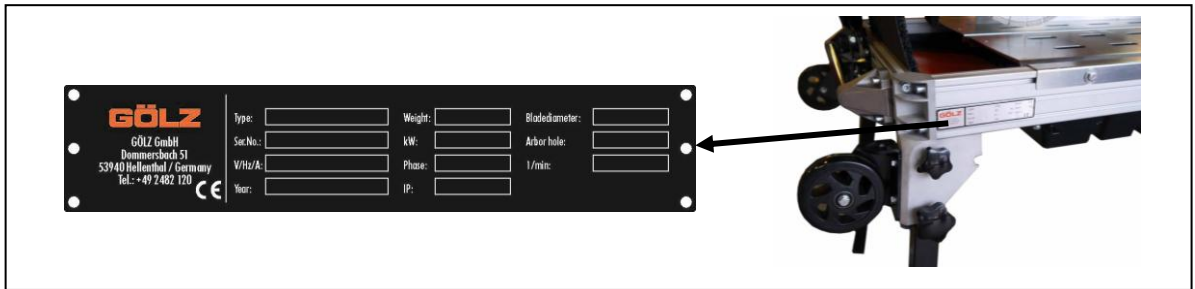

## 4.10 Requirements for the installation site

The substrate for the installation must:

- ▶ have sufficient load carrying capacity.
- ▶ have a non-slip surface.
- ▶ be even.

### Installation conditions

- ▶ Select the installation site according to the required space according to the technical data.



#### NOTE!

*The machine is designed for daylight use. In case of poorly lit or unlit working areas, ensure sufficient workplace illumination.*

## 4.11 Storage requirements

### Storage conditions

Always store the machine, components, assemblies or parts only under the following conditions:

- ▶ Do not store outdoors
- ▶ Store dry and dust-free
- ▶ Do not expose to aggressive media
- ▶ Protect from solar radiation
- ▶ Avoid mechanical shocks
- ▶ Storage temperature 5 °C to 45 °C
- ▶ Relative air humidity, max. 60

When storing for longer than 3 months, regularly check the general condition of all parts and the packaging. If necessary, refresh or renew the preservation.

## 5 Design and function

The machine consists of the base frame with swing-out legs including the installed technology, the motor, the cutting table, the cutting disk protection hood with cutting disk, and the water tank with water pump.

### 5.1 Scope of delivery and responsibilities

The machine was developed and built under the sole responsibility of Gölz GmbH.

After handover to the operator, the responsibility for safe handling and instruction of the operating personnel is transferred to the operator.

The manufacturer offers training on the machine.

The following components are included in the scope of delivery:

<b>Component</b>	<b>Qty</b>
Bridge saw GS350A-120	1
Technical documentation	1

<b>Optional accessories</b>	<b>Qty</b>
Transport wheels Support leg	1
Lateral roll jib	1
Lateral jib	1
T-Lock tile clamping device	1
Tile stop 1m	1

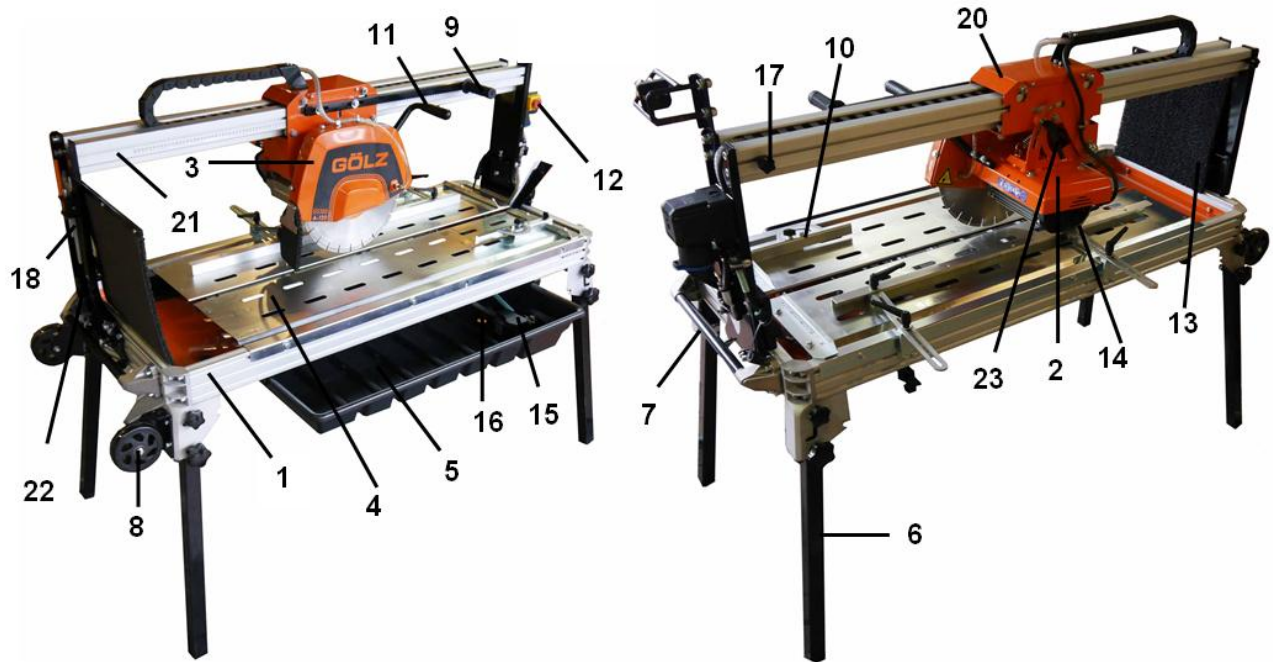

1	Base frame	9	Handle long	17	Transport security
2	Cutting head	10	Stop bracket	18	Tool holder
3	Tool holder	11	Cutting head handle	20	Cutting head mounting
4	Cutting table	12	Connector / Switch (emergency stop & main switch)	21	Guide bridge
5	Water sump	13	Splash guard	22	Angle adjustment
6	Pillars	14	Motor	23	Locking lever
7	Transport handle	15	Water pump		
8	Transport wheels	16	Drain plug		

### Base frame

The base frame (1) is a robust aluminium construction.

### Guide bridge with cutting head

The cutting head holder (20) is a welded steel construction and moves over the guide bridge (21). The cutting head (2), drive motor (14) and cut-off wheel guard (3) are attached to the cutting head holder. The guide bridge can be swivelled steplessly up to 45° (jolly) via the angle adjustment (22) and thus enables mitre cuts. The cutting head holder can be fixed by means of transport locks (17). The cutting head can be easily adjusted and moved with the cutting head handle (11).

### Cutting blade protective cover

The cut-off wheel protective cover (3) protects against contact with the cut-off wheel and against hazardous parts being thrown out. It must always be fitted during operation! The cut-off wheel protective cover can be opened to change the cut-off wheel. The direction of rotation of the cut-off wheel is marked with an arrow on the cut-off wheel protective cover.

### Cutting table

The cutting table (4) is an extremely stable support table. Wide openings allow the water to flow back into the water tray (5). The cutting table can be easily removed for cleaning.

### Cooling water supply

An electric water pump (15) in the water pan (5) provides the cooling water supply and transports the cooling water from the water pan to the cutting wheel. A sufficient water supply results in a longer service life of the cut-off wheel and dust binding. The water supply can be adjusted via the tap on the cut-off wheel protective cover. The water pump must never run dry. The water pan can be emptied via a drain plug (16).

### Electric motor and switch-plug combination

Electric motor with 2,2kW. The motor has a thermal overload protection which trips if the motor is overheated. The machine can only be restarted when the engine temperature has dropped and is within the operating temperature range.

Switch-plug combination (12) with built-in undervoltage release which prevents the motor from restarting after a power failure. After a power failure, the machine must be restarted manually. The switch is equipped with an emergency stop function. After actuating the emergency stop flap, it locks and immediately disconnects the motor from the power supply so that the machine comes to a standstill. A restart of the machine is only possible after unlocking the emergency stop flap.



**NOTE!**

*For design reasons, the emergency stop function flap is located directly above the main switch. An impact on the outer function flap causes an emergency stop. By opening the flap on this switch, the machine can be switched off via the main switch.*



**NOTE!**

*After switching on the machine, the cut-off wheel starts to rotate immediately!*

## 5.2.1 Functional description

The bridge saw is exclusively intended to cut building materials in the sizes specified under →Technical data.

The responsible operating personnel places the products on the machine by hand.

Fix the cutting head to the desired cutting depth by means of the cutting head handle and locking lever.

Only move the cutting head over the attached handles.

By pressing the main switch, the machine starts the electric motor and the cutting disc starts rotating immediately. The water supply must then be switched on separately via the water pump switch located below the main switch. The water supply can be adjusted via the water tap on the cut-off wheel guard.

The cutting head is pulled slowly through the material by the handles until the rear stop point of the cutting head is reached. The cutting speed of the cutting process is controlled manually.

When the cutting process is finished, the motor is switched off via the main switch, the water supply is interrupted by pressing the switch of the water pump.

## 6 Transport & Packaging

### 6.1 Safety instructions for transport



**CAUTION!**

**Damage due to improper transport!**

Improper transport can cause considerable damage to the transported goods and objects in the vicinity.

- Always proceed with the greatest care and caution when loading, unloading and internal transport of goods.
- Observe the instructions and symbols on the packaging.
- Always remove transport locks only during assembly.

### 6.2 Transport Inspection

Check the condition of the transport goods immediately upon receipt of the delivery for completeness and damage.

For externally visible transport damage:

- ▶ Do not accept delivery or accept it only under reserve.
- ▶ Enter the extent of damage on the transport documents and note it on the carrier's delivery note.
- ▶ Initiate complaint.



**NOTE!**

*Complain about any defect immediately upon receipt of the goods!*





*Claims for damages due to transport damage can only be made within the valid complaint periods.*

### 6.3 Transport symbols

According to the contents, there are symbols on the outside of the transported goods which must be observed during transport and storage.

**Meaning of the transport symbols**

The following transport symbols can be found on transported goods:

	<p><b>Top</b></p> <p>The arrowheads mark the top of the transported goods. They must point upwards, otherwise the contents may suffer damage.</p>		<p><b>Protect from moisture</b></p> <p>Protect transported goods from moisture and keep them dry.</p>
	<p><b>Attachment point</b></p> <p>Attach slings only at the marked points.</p>		<p><b>Focal point</b></p> <p>Indicates the centre of gravity of the transported goods. Observe the centre of gravity position when lifting and transporting!</p>

## 6.4 Transportation and storage

### Handling the packaging

The machine is packed safely and in an environmentally friendly manner for the expected transport conditions. The packaging protects the components from damage and corrosion until the start of assembly.

- ▶ Do not remove packaging and transport locks until before installation.
- ▶ Dispose of packaging material according to local regulations.



#### **CAUTION!** **Environmental damage due to incorrect disposal!**

Packaging materials are valuable raw materials and can be reused or sensibly processed and recycled.

- Always dispose of packaging material in an environmentally friendly manner.
- Observe local regulations, if necessary commission a specialist company with the disposal.

### Transport of the machine



#### **CAUTION!** **Damage due to improper transport!**

Improper transport can cause considerable damage to the machine and nearby objects.

Before every transport:

- the cutting head must be secured using the transport lock
- the cutting head must be lowered and locked
- the machine must be de-energized

The machine can be transported by one person using the attached transport rollers or by two persons using the transport handles.



#### **NOTE!**

*The machine is not designed for crane transport! There are no suitable load carrying points on the machine.*

## Storage of the machine

Store the machine under the following conditions:

- ▶ Do not store outdoors
- ▶ Store dry and dust-free.
- ▶ Do not expose to aggressive media.
- ▶ Protect from solar radiation.
- ▶ Avoid mechanical shocks.
- ▶ Storage temperature: 5 to 45 °C.
- ▶ Relative humidity: max. 60 %.
- ▶ If stored for longer than 3 months, regularly check the general condition of all parts and the packaging. If necessary, refresh or renew the preservation.



**NOTE!**

*Only store cut-off wheels upright or suspended!  
Protect from moisture!*

## 7 Installation and initial commissioning

### 7.1 Safety Instructions for Installation



**WARNING!**  
**Risk of injury due to improper installation!**

Improper execution of work and errors during installation can lead to serious injuries at work and life-threatening situations during commissioning and operation.

- Any installation work may only be carried out by trained personnel authorised by the operator.
- Ensure that there is sufficient clearance for installation before starting work.
- Always pay attention to order and cleanliness in the working area!



**DANGER!**  
**Danger to life from electric current!**

Touching live parts leads to death. Damage to the insulation or individual components can be life-threatening.

- Connection, testing and measuring activities on electrical parts may only be carried out by qualified electricians.
- If electrical components are defective, switch off the power supply immediately and arrange for repair.
- Keep moisture away from live parts.

### 7.2 Setting up

Place the machine in a suitable place. Ensure that the cutting head is secured by the transport lock. To facilitate set-up, the cutting head can be fixed to the respective attachment points to set up the machine on the opposite transport handles. Check that the machine is in a secure position before putting it into operation.

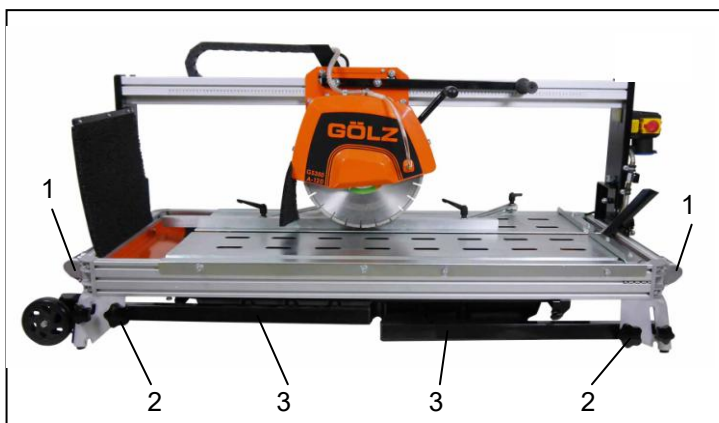

- ▶ Loosen the star knob screw (2) and lift the machine over the transport handles (1)
- ▶ Fold the support legs (3) in or out and make sure that the support legs are in the catch.
- ▶ To secure, retighten the star grip screws (2).

#### Personal protective equipment

- ▶ Protective clothing
- ▶ Protective gloves
- ▶ Safety shoes

## 7.3 Connect

Before connecting the machine to a power source, make sure the following:

- ▶ The voltage / phase of the supply corresponds to the specifications on the motor and machine nameplate
- ▶ The existing power line must be earthed in accordance with the safety regulations
- ▶ Sufficient cable size of the extension cable, H07RNF 3x2.5 mm<sup>2</sup> up to 50 m for 230V



**NOTE!**

*With a cable length >50m there may be a loss of performance on the machine!*

### Personal protective equipment

- ▶ Protective clothing
- ▶ Protective gloves
- ▶ Safety shoes
- ▶ Ear protection
- ▶ Safety goggles

## 7.4 Initial commissioning and acceptance, general



**DANGER!**

**Risk of injury during initial commissioning or adjustment work. Therefore:**

- Before starting work, put the machine out of operation and secure it against being switched on again. Attach warning signs!
- Ensure that the machine does not stand on slopes or pit edges
- Pay attention to a straight underground
- Ensure adequate lighting
- Keep the environment clean and free from objects and lines
- Ensure that no unauthorised persons are present in the machine area



The machine is delivered fully assembled. However, the cut-off wheel and the stop angle must still be fitted. The support legs must be folded out.

## 7.4.1 Measures before initial commissioning

### 7.4.1.1 Mounting the cut-off wheel

To install a new cut-off wheel or change a used cut-off wheel, proceed as follows:

1. switch off the machine and disconnect the power supply by pulling the power cord
2. loosen the screws on the cut-off wheel protective cover so that you can remove the front half of the cut-off wheel protective cover
3. loosen the nut from the motor shaft and remove the outer cutting flange
4. clean the cutting flange, nut and motor shaft
5. check the components for signs of wear
6. mount or replace the cut-off wheel. Make sure that the cut-off wheel and the motor shaft rotate in the correct direction



**NOTE!**

*The direction of rotation arrow on the blade indicates the correct direction of rotation.*

7. place the outer cutting flange back onto the motor shaft
8. screw the nut back onto the motor shaft and tighten
9. put the front cutting disc cover back on the rear cutting disc cover
10. retighten the screws on the cut-off wheel protective cover



**NOTE!**

*The cutting disc must not touch the table, regardless of its position or the position of the cutting head!*

### 7.4.1.2 Filling the water sump

Before starting the machine, the water tray must be filled with water. Use clear, clean water.



**ATTENTION!**

The water pump must not run without water, otherwise it may be damaged.



**NOTE!**

*Make sure that cooling and rinsing water as well as cutting slurries remain. These must be collected, filtered and disposed of accordingly.*

## 8 Operating

### 8.1 Safety instructions for operation



#### **WARNING!**

#### **Risk of injury due to improper operation!**

Improper operation can lead to serious injuries.

- Operation may only be carried out by trained personnel authorised by the operator.
- Before carrying out any work, ensure that the safety devices are correctly installed and function properly.
- Never override safety devices.
- Always pay attention to order and cleanliness in the working area! Loose objects, components, workpieces, tools and cleaning equipment lying around are sources of accidents.



#### **DANGER!**

#### **Danger to life from electric current!**

Touching live parts leads to death. Damage to the insulation or individual components can be life-threatening.

- If electrical components are defective, switch off the power supply immediately and arrange for repair.
- Keep moisture away from live parts.

#### **Personnel**

- ▶ Instructed personnel

#### **Personal protective equipment**

- ▶ Protective clothing
- ▶ Protective gloves
- ▶ Safety shoes
- ▶ Ear protection
- ▶ Safety goggles

### 8.2 Intended working position of the operator

The operator stands in front of the machine near the emergency stop switch, so that he can push the cutting head back and forth by means of the corresponding handle, and also to trigger the emergency stop at any time in emergency situations.



## 8.3 Preparations for launch

To use the machine safely and for its intended purpose, the following requirements must be met:

- ▶ The machine stands securely
- ▶ The water tray is filled with clean, clear water
- ▶ The machine was checked for damage, loose screw connections and for completeness
- ▶ The water supply is functional
- ▶ The direction of rotation arrow on the cut-off wheel and the cut-off wheel protective cover must correspond
- ▶ A suitable blade, which meets the optimum conditions, must be fitted

## 8.4 Switch on

The machine is switched on via the main switch. To do this, open the emergency stop function flap and press the green button.



### *NOTE!*

#### *Check after start:*

- The cooling water must be conveyed in sufficient quantity from the water pump to the cut-off wheel and discharged on both sides. Ist dies nicht der Fall, Maschine sofort stoppen!

The motor is equipped with a thermal protection which is activated in case of a too high temperature rise.

Before restarting the machine, wait about 30 minutes until the motor has cooled down.

## 8.5 Cutting process

### 8.5.1 Normal cuts with 90° adjustment

When used in 90° position, the cutting head is in the fixed position. Proceed as follows for adjustment:

1. switch off the machine -> the cutting disc must not turn!
2. loosen the adjusting screw
3. place the cutting head in the desired position



**NOTE!**

*The cutting disc must not touch the table, regardless of its position or the position of the cutting head!*

4. tighten the adjusting screw -> check that the cutting head is fixed in height and cannot move
5. place the material to be cut on the table
6. check the position of the material using the angular stop.
7. start the engine and the water pump and open the water tap
8. Grasp the chain-guided crank handle on the cutting head with your right hand and the transport handle on the machine frame with your left hand



**NOTE!**

*In an emergency, use your left hand to operate the emergency stop button on the switch.*

9. Then crank the cutting head slowly and without pressure through the loaded material. The cutting disc will then cut through the material

## 8.5.2 45°- bevel cuts

The machine offers the possibility to perform 45° bevel cuts.

For 45° bevel cuts we proceed as follows:

1. switch off the machine -> the cutting disc must not turn!
2. loosen the star knob screws on the bridge on both sides of the machine
3. swivel the complete cutting head with bridge into the desired position. Use the scale on the side for orientation.
4. retighten the star knob screws.
5. next, loosen the adjusting screw.
6. adjust the depth stop and fix this setting



**NOTE!**

*The cutting disc must not touch the material to be cut or the fence angle, regardless of its position or the position of the cutting head!*

7. place the material to be machined on the table Check the position of the material using the angle stop.
8. start the engine and the water pump and open the water tap
9. grasp the chain-guided crank handle on the cutting head with your right hand and the transport handle on the machine frame with your left hand



**NOTE!**

*In an emergency, use your left hand to operate the emergency stop button on the switch.*

10. Then crank the cutting head slowly and without pressure over the loaded material. The cutting disc will then cut through the loaded material.

To return the guide bridge with cutting head to the 90° position after this cutting operation, proceed as follows:

1. switch off the machine -> the blade must not turn!
2. loosen the star knob screws on the bridge on both sides of the machine
3. swivel the complete cutting head with guide bridge into the desired position
4. tighten the star knob screws again.



**NOTE!**

*Hold the cutting head in the 90° position with one hand. Tightening the nut could reverse the angle so that the cutting head is not exactly at 90°.*



**NOTE!**

*The cutting wheel must not touch the material to be cut, regardless of its position or the position of the cutting head!*

## 8.5.3 Water supply

Heavily contaminated water reduces the service life of the water pump and the cut-off wheel.

- ▶ If used frequently, change the water several times a day and collect, filter and properly dispose of the cutting sludge
- ▶ Clean the suction strainer of the water pump with each water change

## 8.6 Ending the cutting process

To stop the machine, open the emergency stop cover of the switch and press the red button.



**NOTE!**

*For design reasons, the emergency stop function flap is located directly above the main switch. An impact on the outer function flap causes an emergency stop. By opening the flap on this switch, the machine can be switched off via the main switch!*

## 9 Maintenance & Cleaning

### 9.1 Safety instructions for maintenance

**WARNING!****Risk of injury due to improper maintenance!**

Improper maintenance can lead to injuries.

- Maintenance work may only be carried out by trained specialist personnel authorised by the operator.
- Ensure that there is sufficient clearance for installation before starting work.

**DANGER!****Danger to life from electric current!**

Touching live parts leads to death. Damage to the insulation or individual components can be life-threatening.

- Before maintenance and repair work, switch off the electrical system and secure it against being switched on again.
- Keep moisture away from electrical components.

**WARNING!****Risk of injury due to incorrect spare parts!**

Faulty spare parts can seriously impair safety and cause damage, malfunctions or even total failure.

- Only use original spare parts.

**CAUTION!****Risk of injury through cuts!**

Reaching into moving tools can lead to serious injuries.

- Never touch the rotating blade
- If work in the machine is necessary, disconnect the machine from the power supply

### 9.2 Maintenance plan

The following sections describe the maintenance operations required for optimum and trouble-free operation.

- ▶ If increased signs of wear on the components are detected during the regular inspections, shorten the maintenance intervals on the basis of the actual signs of wear!
- ▶ Draw up a maintenance log for each maintenance work! The protocol helps with error analysis, enables the adjustment of the required intervals to the actual operating conditions and possible warranty claims.
- ▶ For questions about maintenance work and intervals: contact the manufacturer.

Interval	Maintenance work	Personnel
Before each commissioning	Optical control - of the complete machine - the tool holder (flanges and blade holder) - of the tool (blade) - the operating elements (handles, wheels, etc.) - the water tray and hoses - of the cutting head and cutting material table	Operating personnel
	Optical control - the electrical system - of the engine - the water pump	Technical staff
	Clean the tool holder (flanges and blade holder)	Operating personnel
	Check tool (blade) for replacement	Operating personnel
	cutting head, cutting table and chain - Lubrication - Grease - Oiling - Apply corrosion protection	Operating personnel
After end of work	Clean up - Entire machine - Control elements (handles, wheels, etc.) - Tools (blade) - cutting head, cutting table and chain	Operating personnel
	Empty and clean the water hoses and water tray	Operating personnel
	Clean up - Motor housing - Water pump	Technical staff
	Tool holder (flanges and blade holder) - Lubrication - Grease - Oiling - Apply corrosion protection	Operating personnel
Weekly	Tightening and adjustment - Control elements (handles, wheels, etc.) - cutting head and chain - Screw connection	Operating personnel
Yearly	Carry out statutory safety inspection for - Electrical system - Engine	Elektrofachpersonal
In case of malfunction	Optical control - of the complete machine - of the cutting head and cutting material table	Operating personnel
	Optical control - the water pump	Technical staff
	Retighten and adjust the cutting head and cutting material table	Operating personnel
In case of damage	Change and exchange - complete machine - Tool holder (flanges and blade holder) - Tool (saw blade) - Operating elements (handles, locking wheels etc.) - Water tray and hoses - Cutting head and cutting material table	Operating personnel
	Change and exchange - Electrical system	- Engine - Water pump Qualified electrical personnel

### 9.3 Description of the maintenance work carried out by the operator

**CAUTION!**

The machine must not be cleaned with a high-pressure cleaner, otherwise the machine will be damaged.

**CAUTION!**

The machine must not be foamed and then sprayed with water, otherwise the machine will be damaged.

**CAUTION!**

The blade must not be cleaned with a metal cleaning device (scraper, metal sponge, or similar), as this will damage it.

#### 9.3.1 Changing the blade

The blade must be replaced when:

- the diamond segments on the blade are completely worn, damaged or broken off
- the material to be cut changes
- the blade runs uneven

#### 9.3.2 Check the water connection

Carry out a visual and audible check that the connections and hoses are tight after each end of work.

#### 9.3.3 Water pump and water sump

- Remove dirty water
- Remove accumulated sludge deposits on the water pan floor
- Remove the water pump and place it in a bucket of clean water.
- Plug in the mains plug and let the machine run for about 1 - 2 minutes.
- Switch off the machine.
- Pull out the mains plug and reinsert the water pump -> this prevents the pump wheel from blocking due to sludge deposits.

### 9.4 Measures after maintenance

After finishing the maintenance work, carry out the following steps before switching on:

1. Check all previously loosened screw connections for tightness.
2. Check that all previously removed guards and covers are properly reinstalled.
3. Ensure that all tools, materials and other equipment used have been removed from the work area.
4. Clean the working area and remove any leaked substances such as liquids, processing material or similar.
5. Ensure that all safety devices of the system function properly.

### 9.5 Note on components subject to wear and tear

Components of this machine that are susceptible to wear:

- Rubber sheets
- Hoses
- Couplings
- Slide bearing
- Spring
- Guide spindle
- Eccentric spindle
- Sticker
- Splash guard
- Pump housing with strainer
- Water pump
- Transport wheels
- Handle cover
- Stopper
- Rubber strip
- Guide rail
- Capacitor
- Fan cover
- Needle bearing
- Bearing bush
- Stock
- Ball valve
- Spacer
- Rubber buffer
- Cable protection

Wear of these components does not constitute a product defect.



**NOTE!**  
*Wearing parts are shaded grey in the spare parts list!*

## 10 Faults

### 10.1 Safety Instructions for Troubleshooting

**WARNING!****Risk of injury due to improper troubleshooting!**

Incorrect execution of work during troubleshooting can lead to serious injuries.

- Repair work may only be carried out by trained specialist personnel authorised by the operator.
- Ensure that there is sufficient clearance for installation before starting work.
- Always pay attention to order and cleanliness in the working area! Loose objects, components, workpieces, tools and cleaning equipment lying around are sources of accidents.
- If components have been replaced, check that the spare parts have been fitted correctly. Install all fasteners correctly. Observe screw tightening torques.
- Before recommissioning, ensure that all protective devices are correctly installed and functional.

**WARNING!****Risk of injury from unauthorized restarting!**

When working on individual components, persons can be injured by unexpectedly switching on the power supply.

- Before carrying out any work on individual components, switch off the power supply and secure it against being switched on again.

**DANGER!****Danger to life from electric current!**

Touching live parts leads to death. Damage to the insulation or individual components can be life-threatening.

- Before maintenance and repair work, switch off the electrical system and secure it against being switched on again.
- Keep moisture away from electrical components.

### 10.2 Behaviour in case of disturbances

Basically the following applies:

1. immediately initiate an emergency stop in the event of faults which pose an immediate danger to persons or property
2. switch off all power supplies and secure against being switched on again
3. inform the person in charge at the place of operation.
4. depending on the type of fault, have the cause determined and rectified by authorised specialist personnel.

## 10.3 Fault table

Error message / fault	Possible cause	Removal	Personnel
Machine without function when switched on	Power plug not properly secured	Check proper connection to the power supply	Operating personnel
	Power plug defective	Check mains plug for function, replace if necessary	Qualified electrical personnel
	Loose connection in the electrical system	Have the entire electrical system of the machine checked by	
	Drive motor defective	Have drive motor checked, replace if necessary	
	Main switch defective	Have the main switch checked and replaced if necessary.	
Machine does not have sufficient power	Power plug too long, cable drum in rolled up condition	Observe the prescribed length of the mains plug. Unwinding the cable drum	Operating personnel
	Power of the local grid is not sufficient	Observe and adhere to the connection data of the machine	Qualified electrical personnel
	Drive motor no longer holds speed	Have drive motor checked, replace if necessary	
Little or no cooling water flow	The water pump sucks air	Fill up with water; swing the water pump with the suction side down	Operating personnel
	Hoses clogged	Clean hoses	
	Hose kinked	Check the routing of the hoses	
	Hose leaking or detached	Replace hose or fasten correctly	
	Pump wheel of water pump dirty (strainer)	Clean pump wheel or strainer	
	Water pump without function	Have the electrical supply line to the water pump checked, replace if necessary	Qualified electrical personnel
Motor does not run	Power plug not connected correctly.	Check mains plug for correct connection	Operating personnel
	Fuse on the site distribution board has triggered	Check fuses	
Saw blade wobbles	Blade tension is poor	Send in saw blade	Manufacturer
Segments come loose	Overheated, insufficient cooling	Check cooling water supply	Operating personnel
		Resolder segments	Manufacturer

<b>Fehlermeldung / Störung</b>	<b>Mögliche Ursache</b>	<b>Beseitigung</b>	<b>Personal</b>
High segment wear	Segment binding too soft	Use blade with harder segments, or reduce feed pressure	Operating personnel
	Segments too narrow in relation to motor power and feed pressure	Reduce feed pressure, or use blade with wider segments	
	Number of segments too low	Use blade with more segments, or reduce feed pressure	
	Blade beats	Use new blade, have old one straightened, check cutting shaft, use new one if necessary	
	Blade runs	Check table guide, replace if necessary	
	Abrasive aggregates	Use blade with harder segments	
	Feed pressure too high	Reduce feed pressure	
Saw blade has lateral and vertical runout	Saw blade bent or damaged	Have the saw blade straightened, solder segments onto new blade or new saw blade	Manufacturer
	Flanges dirty or damaged	Clean or replace flanges	Operating personnel
	The motor shaft is bent	Replace the electric motor	Qualified electrical personnel
No power when cutting, saw blade blunt	No saw blade matched to the material	Use the correct saw blade	Operating personnel
	No saw blade matched to the machine output		
	Saw blade too hard		
	Diamonds on segment are blunt	sharpen	Technical staff
Cutting process not optimal	Segments blunt	sharpen	Technical staff
	Saw blade too heavily loaded	Use a suitable saw blade	Operating personnel
	Saw blade tension bad	Send in saw blade	Manufacturer
The mounting hole of the saw blade has run out	Saw blade has rotated on the motor shaft	Check the mounting flange, if necessary exchange	Manufacturer
		Unscrew the location hole and fit the exact ring	Technical staff

<b>Fehlermeldung / Störung</b>	<b>Mögliche Ursache</b>	<b>Beseitigung</b>	<b>Personal</b>
Saw blade has started up	Saw blade overheats too little cooling water	Check cooling water supply	Operating personnel
	Lateral friction due to the course of the cut	Reduce feed rate, pull material through slowly	
Cracks in the steel core; eccentric wear on the saw blade	Saw blade too hard	Use softer saw blade	Operating personnel
	Motor shaft bearing	Replace the motor shaft bearing	

## 10.4 Measures to be taken after the fault has been rectified

After completing the troubleshooting, carry out the following steps before switching on:

1. check all previously loosened screw connections for tightness.
2. check that all previously removed guards and covers are properly reinstalled
3. ensure that all tools, materials and other equipment used have been removed from the work area.
4. clean the work area and remove any leaked substances such as liquids, processing materials or similar.
5. make sure that all safety devices of the machine work properly.

## 11 Disassembly and disposal

After reaching the designed service life, the machine must be dismantled and disposed of in an environmentally friendly manner.

### 11.1 Safety instructions for disassembly and disposal

**WARNING!****Risk of injury in case of improper disassembly!**

Improper work during disassembly can lead to serious injuries.

- Dismantling work may only be carried out by trained specialist personnel authorised by the operator.
- Ensure sufficient freedom of assembly before starting work.
- Always pay attention to order and cleanliness in the working area! Loose objects, components, workpieces, tools and cleaning equipment lying around are sources of accidents.
- Caution on sharp-edged components, corners and tips.
- When dismantling, always secure components so that they do not fall down or overturn.
- Dismantle components properly and professionally in compliance with local occupational safety and environmental protection regulations.
- Contact the manufacturer if anything is unclear.

**DANGER!****Danger to life from electric current!**

Touching live parts leads to death.

Damage to the insulation or individual components can be life-threatening.

- Before disassembly, switch off the electrical power supply and secure it against being switched on again.

**Personnel**

- ▶ Instructed and qualified personnel authorised by the operator

### 11.2 Disassembly

1. switch off the machine and secure it against being switched on again.
2. physically disconnect the entire power supply from the device, discharge residual energy. Check freedom from voltage and pressure.
3. remove operating and auxiliary materials and remaining processing materials and dispose of them in an environmentally friendly manner.
4. clean assemblies and components properly and dismantle them in accordance with the applicable local occupational safety and environmental protection regulations.

### 11.3 Disposal

If no take-back or disposal agreement has been concluded, supply dismantled components for recycling:

- ▶ Scrapping metallic residues.
- ▶ Give plastic parts for recycling.
- ▶ Dispose of other components sorted according to material properties.



## Just for EU-Countries

Old electrical appliances are recyclable materials and therefore do not belong in the household waste!

According to the European Directive 2012/19/EU on Waste Electrical and Electronic Equipment and its implementation in national law, used power tools must be collected separately and recycled in an environmentally friendly manner.



### **CAUTION!**

#### **Environmental damage due to incorrect disposal!**

Incorrect or negligent disposal can cause considerable environmental pollution.

- Have electronic waste, electronic components, lubricants, operating materials and other auxiliary materials disposed of by specialist companies.
- Observe the treatment and disposal instructions in the safety data sheets for hazardous substances.
- In case of doubt, consult the manufacturer or obtain information from local authorities or specialist disposal companies on environmentally sound disposal.

## 12 Spare parts list

### 12.1 Use of the spare parts list

The spare parts list is not an assembly or disassembly instruction. The spare parts list serves exclusively to find spare parts quickly and easily, which can be ordered from the sales offices.



**DANGER!**  
**Risk of injury from mounting or dismounting assemblies!**

Using the spare parts list for assembly or disassembly purposes can lead to serious personal injury or even death!

- For assembly and disassembly work, only the corresponding descriptions in the operating instructions must be followed.

### 12.2 Sales offices

**Deutschland - Germany - Allemagne - Duitsland**

GÖLZ® GmbH  
 Dommersbach 51  
 DE-53940 Hellenthal  
 Tel: +49 (0)2482-12 200  
 Fax: +49 (0)2482-12 222  
 E-Mail: [info@goelz.de](mailto:info@goelz.de) / Internet: [www.goelz.de](http://www.goelz.de)

**Österreich - Austria - Autriche - Oostenrijk**

GÖLZ® Ges.m.b.H  
 Samstraße 52  
 A-5020 Salzburg  
 Tel: +43 (0) 662 - 43 81 75  
 Fax: +43 (0) 662 - 43 07 34  
 E-Mail: [info@goelz.at](mailto:info@goelz.at) / Internet: [www.goelz.at](http://www.goelz.at)

**Frankreich - France - France - Frankrijk**

GÖLZ® S.A.S.  
 1, rue de la Mairie  
 F-67370 Berstett  
 Tel: +33 (0)3.88.59.43.00  
 Fax: +33 (0)3.88.59.47.77  
 E-Mail: [info@golz.fr](mailto:info@golz.fr) / Internet: [www.golz.fr](http://www.golz.fr)

**Großbritannien - Great Britain - Grande-Bretagne - Groot-Brittannië**

GÖLZ® (UK) Ltd.  
 Unit A5, Springhead, Enterprise Park  
 Northfleet  
 Kent DA11 8HB  
 Tel: +44 1 474321679  
 Fax: +44 1 474321477  
 E-Mail: [info@goelz.co.uk](mailto:info@goelz.co.uk) / Internet: [www.goelz.co.uk](http://www.goelz.co.uk)

**Benelux**

GÖLZ® Benelux  
 Eupener Straße 61  
 BE-4731 Raeren-Eynatten  
 Tel: +49 (0)2482-12 200  
 Fax: +49 (0)2482-12 222  
 E-Mail: [benelux@goelz.de](mailto:benelux@goelz.de) / Internet: [www.goelz-online.com](http://www.goelz-online.com)

**Australien - Australia - Australie - Australië**

GOLZ® Pty Ltd.  
 44 Stanley Street  
 Peakhurst, NSW 2210  
 Tel: +61 (0) 2 9534 5599  
 Fax: +61 (0) 2 9534 5588  
 E-mail: [info@golz.com.au](mailto:info@golz.com.au) / Internet: [www.golz.com.au](http://www.golz.com.au)



**USA**

GOLZ® L.L.C.  
 5860 East Osage Ridge Lane  
 Columbia MO 65203-6018  
 Tel: +1 573 474 4961  
 E-Mail: [info@golzusa.com](mailto:info@golzusa.com) / Internet: [www.goelz-online.com](http://www.goelz-online.com)



**NOTE!**

*To avoid wrong deliveries, the details in the order should be checked for correctness and completeness before dispatch! Complete delivery address!*

		
<p><b>So bekommen Sie schnell und richtig Ihr Ersatzteil</b></p>	<p><b>Always indicate</b></p>	<p><b>Pour obtenir rapidement les pièces de rechange indiquer</b></p>
<ul style="list-style-type: none"> <li>• Maschinentyp gemäß Typenschild</li> <li>• Baujahr gemäß Typenschild</li> <li>• Artikelnummer gemäß Ersatzteilliste</li> <li>• Maschinenummer gemäß Typenschild</li> </ul>	<ul style="list-style-type: none"> <li>• machine type according to nameplate</li> <li>• year of manufacture according to nameplate</li> <li>• order number according to spare part list</li> <li>• serial number according to nameplate</li> </ul>	<ul style="list-style-type: none"> <li>• type de la machine conforme de plaque d'identification</li> <li>• Année de construction selon plaque d'identification</li> <li>• Numéro de l'article selon la liste des pièces de rechange</li> <li>• numéro de la machine suivant plaque d'identification</li> </ul>
<p>Für Bestellungen, Fragen und Informationen wenden Sie sich bitte an die zuständigen Stellen.</p>	<p>For orders, questions and information, please contact the competent departments.</p>	<p>Pour les commandes, questions et informations, veuillez-vous adresser aux points de ventes correspondants.</p>

## 13 Wiring diagram

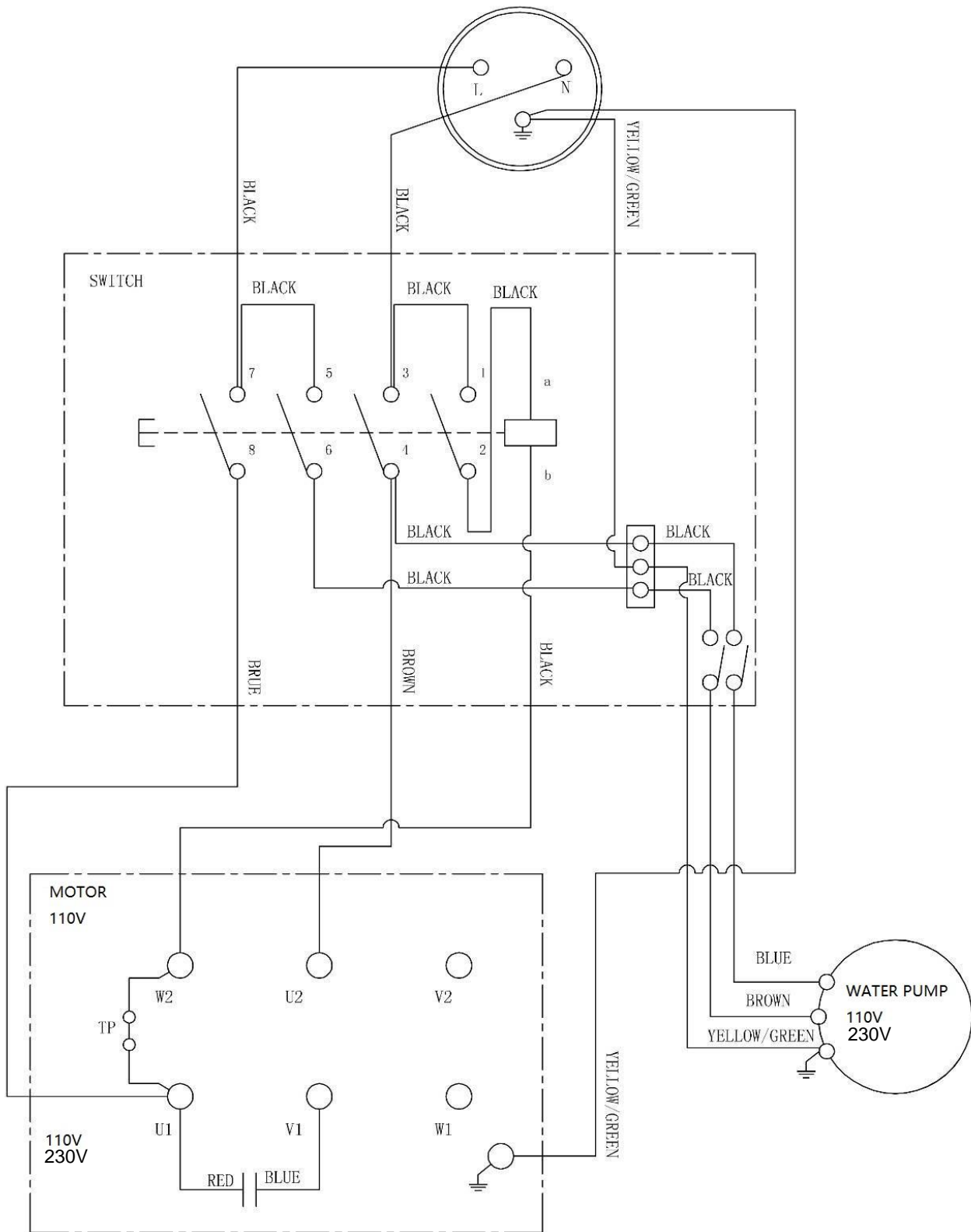

**EU conformity declaration**

**GÖLZ® GmbH**  
 Dommersbach 51  
 D-53940 Hellenthal  
 Deutschland

declares under sole responsibility that

<b>Model:</b>	<b>Bridge Saw</b>
<b>Make:</b>	<b>GÖLZ</b>
<b>Type:</b>	<b>GS350A-120</b>

comply with the relevant provisions of the Directives

<b>2006/42/EC</b>	<b>Machinery directive</b>
<b>2014/30/EU</b>	<b>Electromagnetic compatibility</b>
<b>2014/35/EU</b>	<b>Low Voltage</b>
<b>2005/88/EC</b>	<b>Noise emission</b>
<b>2012/19/EU</b>	<b>Electrical and electronic waste</b>

and has been developed and fabricated in compliance with the following standards valid as at the production date:

<b>DIN EN 12418:2022-07</b>	<b>Masonry and stone cutting-off machines for job site - Safety</b>
<b>DIN EN ISO 12100:2011-03</b>	<b>Safety of machinery - General principles for design</b>
<b>DIN EN ISO 13849-1:2023-12</b>	<b>Safety of machinery - Safety-related parts of control systems</b>
<b>DIN EN 61000-3-2:2019-12; VDE 0838-2:2019-12 DIN EN 61000-3-11:2021-03; VDE 0838-11:2021-03</b>	<b>Electromagnetic compatibility (EMC)</b>
<b>DIN EN 55014-1:2018-08; VDE 0875-14-1:2018-08 DIN EN 55014-2:2022-10; VDE 0875-14-2:2022-10</b>	<b>Electromagnetic Compatibility</b>
<b>DIN EN 60204-1; VDE 0113-1:2019-06</b>	<b>Safety of machinery - Electrical equipment of machines</b>

Technical documentation kept by:

**GÖLZ® GmbH**  
 Development and design

Year of construction and machine number are indicated on the unit.

Hellenthal, 17.12.2024  
 GÖLZ® GmbH

.....  
 Managing Director